

Service

PROCEDURES

PAGE 1/1

SUBJECT

CYLINDER REPLACEMENT

Procedures for replacing a Pacbrake single actuating air cylinder with a double acting air cylinder:

I N S T R U C T I O N S :

- 1 Remove air line at cylinder and save.
- 2 Remove E-clips at clevis and anchor pin ends and save.
- 3 Remove clevis pin and save.
- 4 Rotate actuating arm to stop pin to determine if binding or seizing of the shaft exists. If arm will not move freely, contact Pacbrake Customer Service Department at (800) 663-0096 before proceeding.
- 5 Measure clevis pin to anchor pin dimension with cylinder fully extended and record.
(This is critical for correct operation of Direct Mount models.)
- 6 Remove clevis and locknut and install on new cylinder provided.
- 7 With new cylinder fully extended, adjust clevis to achieve pin-to-pin measurement as recorded above, and securely tighten locknut. Double check pin-to-pin measurement.
- 8 Install the two 90P fittings to cylinder.
- 9 Lubricate anchor pin and clevis pin and install cylinder.
- 10 Remove old solenoid valve and airline. CAUTION: This line may be under pressure.
- 11 Install new solenoid valve provided as shown in illustration.
- 12 Install the original airline and measure amount of wire braid line required for the additional line.
Cut and install the fittings. Using air pressure blow this line out from each end once assembled.
- 13 Install the original air supply line to port #1 on new solenoid valve.
- 14 Connect original power supply to one solenoid wire and the other to a good vehicle ground.

Pacbrake Service

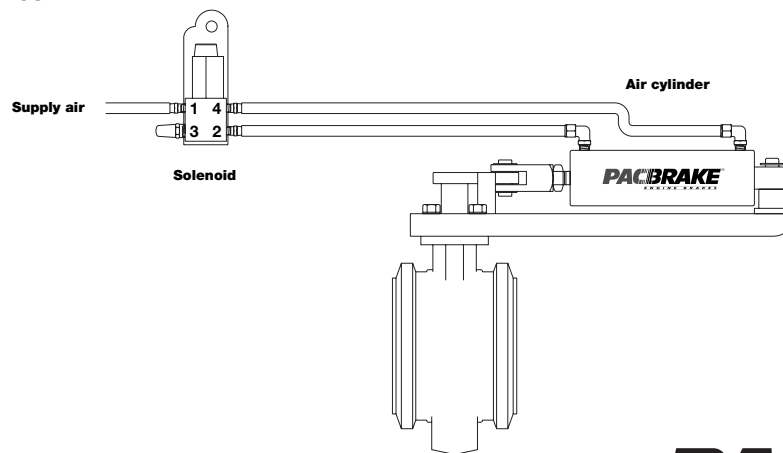

PACBRAKE[®]
ENGINE & EXHAUST BRAKES