

Installation Manual



AIR SPRING KIT

Toyota Tacoma (4WD)*

Toyota Tacoma PreRunner (2WD)*

Use the most advanced air springs on the market to eliminate your vehicle's sag, sway and bottoming out. This heavy duty air suspension kit levels your truck's stance while providing added support for an overall smooth and safe ride.

* See application guide for proper fitment.

L6449_REV6_06.02.2023 ECN 1-2735



WARNING: This product can expose you to the chemical Hexavalent Chromate, which is known to the State of California to cause cancer and birth defects or other reproductive harm. *For more information go to www.P65Warnings.ca.gov*

IMPORTANT

This air suspension kit will not increase the GVWR (*Gross Vehicle Weight Rating*), as the GVWR is determined by the vehicle manufacturer. **Do not exceed the maximum capacity listed by the vehicle manufacturer.**

PLEASE NOTE: *The air bag must have clearance between itself and the surrounding components to prevent any contact when bag is inflated or compressed. Trimming off excess bolt length is also required to ensure no contact with the bag or other suspension components can be made once installed.*

Safety Warnings!

- ❗ Serious personal injury or death may result from an air spring failure or accident due to improper installation or air spring pressure operation or maintenance. Please read and abide the instructions, safety recommendations and maintenance suggestions throughout this manual.
- ❗ Inflating an unsecured air spring is dangerous. If it bursts, it could be hurled into the air with explosive force resulting in serious personal injury or death. Never inflate an air spring unless it is secured to the vehicle.
- ❗ Removing and replacing air springs can be dangerous. This is only a job for a qualified service professional. Never perform air spring service procedures without proper training, tools, and equipment.

KIT CONTENTS

Reference the kit explosion diagram on the following page for part assembly.

KIT CONTENTS		QTY	PART #
A	Air Spring	2	HP10083
B	Roll Plate, 4.5" Diameter	4	HP10054
C	Fitting, 1/4" NPT Brass Straight	2	HP1099
D	Frame Bracket	2	HP1508
E	Top Bracket	2	HP1507
F	Bottom Bracket	2	HP1506
G	Spacer	4	HP0113
H	Bolt, 3/8" - 24 x 3/4" Countersunk	4	HP1008
I	Bolt, 3/8" - 24 x 7/8" Hex Head	4	HP1002
J	Bolt, 3/8" - 16 x 3.5" Carriage	8	HP1332
K	Bolt, 3/8"-16 x 1.5" Hex Head	8	C18018
L	Bolt, 1/2"-13 x 2" Hex Head	2	HP1459
M	J-Bolt	4	HP1976
N	Washer, 3/8" Flat	32	C653
O	Washer, 1/2" x 2" Od Thick Flat	4	HP1369
P	Nut, 3/8" Nylon Lock	20	HP1000
Q	Nut, 1/2" Serrated Flange	2	HP1370
R	Heat Shield	1	HP0012
S	Worm Gear Ring Clamp	2	HP1001

REQUIRED TOOLS

- Hoist or Floor Jack
- Safety Stands
- Safety Glasses
- Torque Wrench
- Standard Combination Wrenches
- 7/32" Hex Allen Wrench
- T40 Torx
- 1-1/8" Wrench or Deep Socket
- Ratchet
- Metric & Standard Sockets
- Hose Cutter (included) or Sharp Utility Knife
- Pipe Thread Sealant
- Spray Bottle with Dish Soap/Water
- Air Compressor/Compressed Air Source (to test/fill air spring)

Please make sure all the items shown in this explosion diagram are provided in your kit before starting the installation.

DRIVER SIDE ASSEMBLY SHOWN:

HOOK J-BOLTS INTO EXTENDED JOUNCE BUMPER STRIKE PAD ON FRAME

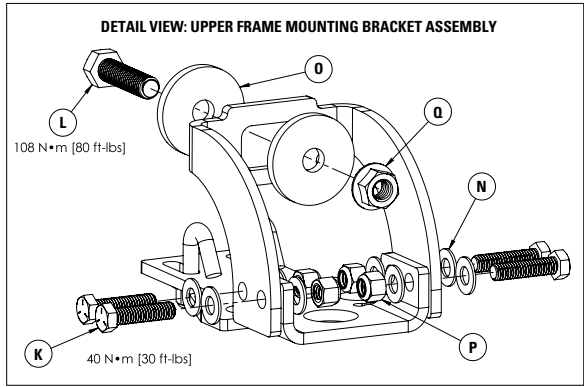
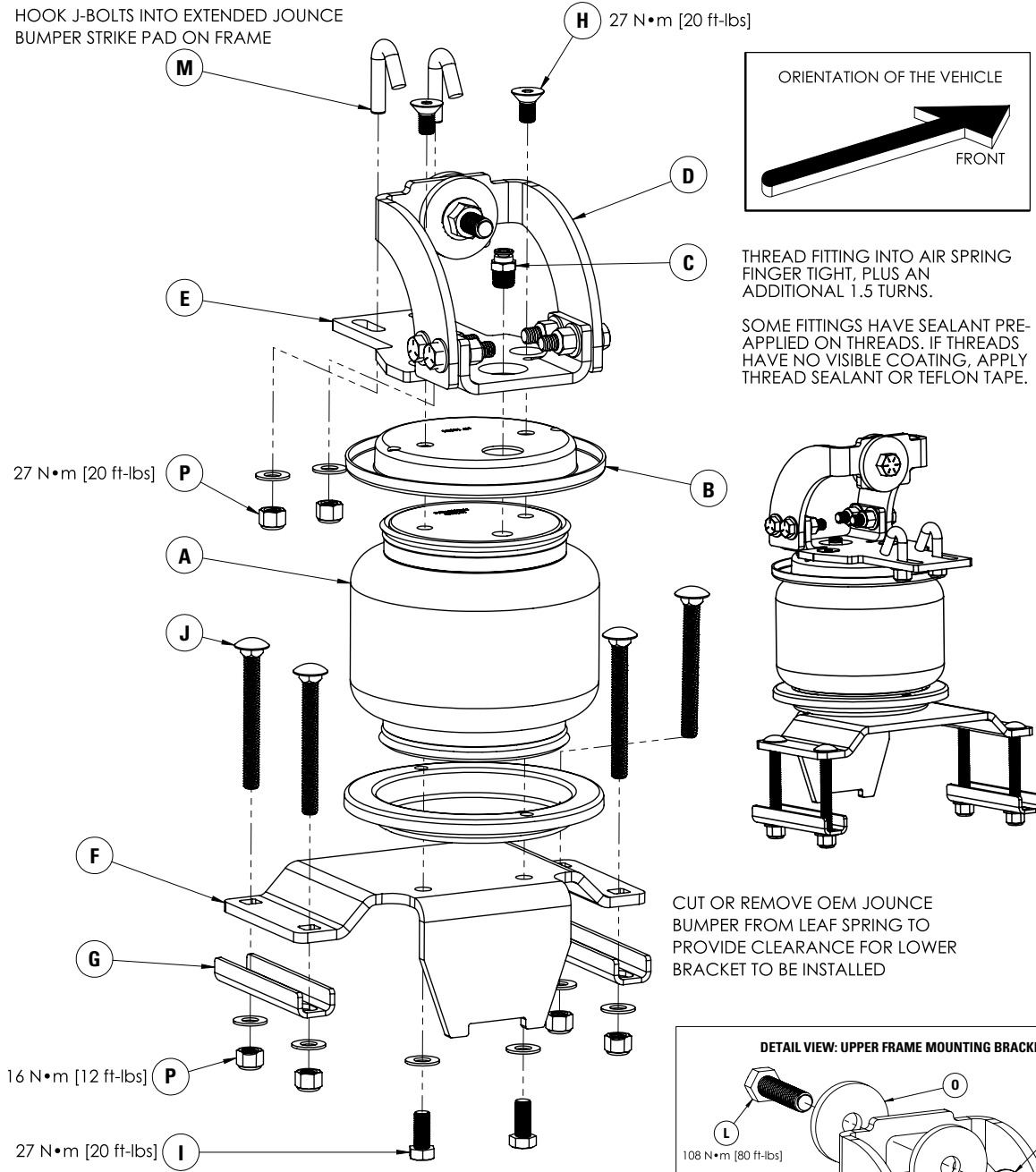

BEFORE STARTING THE INSTALLATION:

1. Ensure the application information is correct for the make, model and year of the vehicle you are installing the kit on.
2. Some vehicles are equipped with a rear wheel brake proportioning valve. Check with the manufacturer before installing the air spring kit, as it may affect braking performance.
3. It is recommended to use a good quality anti-seize on all fasteners. This will reduce the chance of corrosion on the fasteners and will help facilitate removal, if required at a later date.

PLEASE NOTE:

This kit contains push-to-connect fittings; using scissors or wire cutters to cut the nylon airline will distort the line and cause the connection to leak. THE AIRLINE MUST BE CUT OFF SQUARELY WITH THE NYLON HOSE CUTTER PROVIDED IN THIS KIT OR A SHARP UTILITY KNIFE.

1 RAISE THE REAR AXLE:

Remove any unnecessary weight from the vehicle to attain normal ride height. This is important for correct initial air spring setup and adjustment.

Park the vehicle on a level surface.

Record the vehicle's normal ride height, which is the distance between the center of the axle and the horizontal wheel well flange. Ensure both sides are the same before raising the vehicle.

Raise the rear axle high enough to remove both rear wheels and attain a comfortable working height.

Place two jack stands under the axle (as shown in Figure 1A & 1B).

Lower the floor jack until the vehicle axle is supported by the jack stands.

Ensure the normal ride height measurement recorded earlier is the same. Adjust if necessary before proceeding.

Once the rear axle is raised correctly, remove the rear wheels.

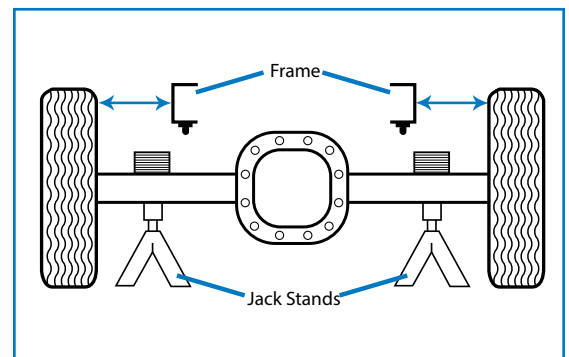
**1A****1B**

2 ASSEMBLING THE AIR SPRING:

⚠ CAUTION: Never back off an installed NPT air fitting. Loosening the fitting will corrupt the seal and contribute to leakage and failure. Apply thread sealant to the fitting threads to prevent leaks and allow for deeper seating of the threads.

Set a Roll Plate on top of the Air Spring (see Figure 2 for assembly). The radiused, or rounded, edge of the Roll Plate should be toward the Air Spring so that it is seated inside the Roll Plate.

Install the Straight Air Fitting into the port on top of the Air Spring, finger tight plus 1 ½ - 3 turns.

Set the Upper Bracket on top of the Air Spring, and install two 3/8"-24 x 7/8" Flat Head Socket Cap Screws through the Upper Bracket, Roll Plate and into the aluminum end cap on top of the Air Spring.

Torque to 27 N•m (20 ft-lbs)

Flip the assembly upside down and set a Roll Plate on the bottom of the Air Spring.

Set the Lower Bracket on top of the assembly and install two 3/8"-24 x 7/8" Hex Head Cap Screws with two 3/8" Washers through the Lower Bracket, Roll Plate, and into the aluminum end cap of the Air Spring.

Torque to 27 N•m (20 ft-lbs)

Repeat this procedure for the second Air Spring Assembly.

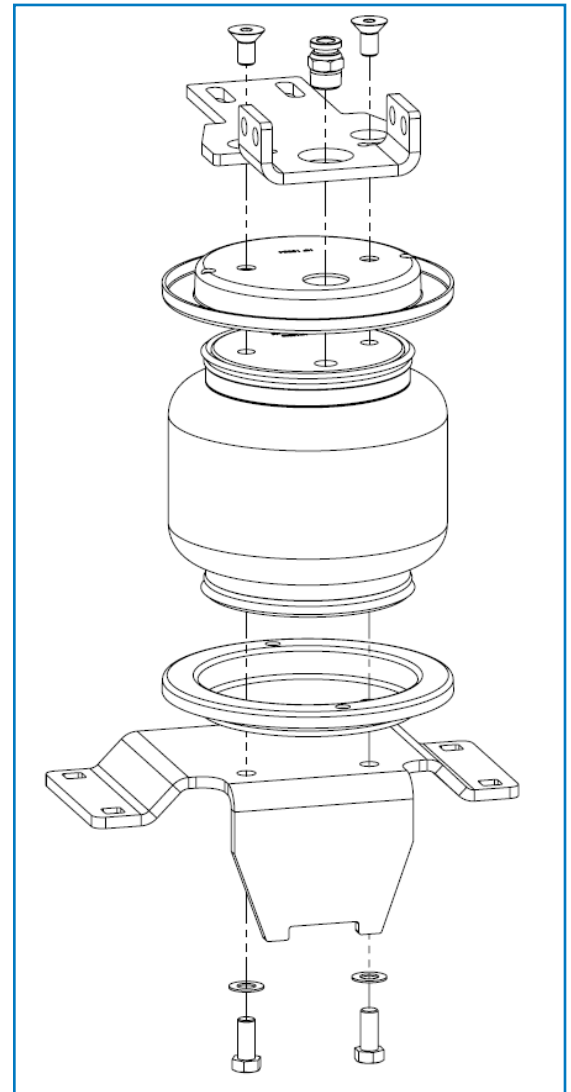

2

3 REMOVE JOUNCE BUMPER

Using a Hacksaw, cut off the rubber jounce bumper parallel with the top of the leaf spring U-Bolts (see Figure 3 for reference).

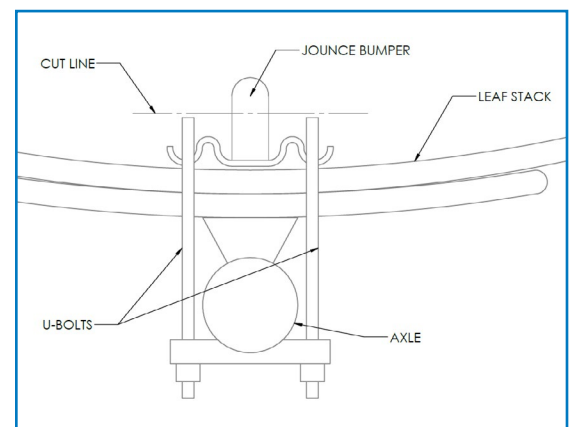

3

4 INSTALLING THE AIR SPRING ASSEMBLIES:

With the vehicle being supported by jack stands, drop the axle or raise the body so that the Air Spring Assemblies can be put into position in between the axle and the frame (reference Figure 4A for part assembly).

Set both left and right side Air Spring Assemblies into position centered over the axle.

Position the Frame Bracket so the large hole is aligned with the large hole in the frame.

Install the ½"-13x2.0" Hex Head Screws, ½" Washers, and ½"-13 Flanged Nut into the large hole.

Torque to 108 N•m (80 ft-lbs)

Fasten the Frame Bracket to the Upper Bracket using the 3/8"-16x1.5" Hex Head Screws, 3/8" Washers, and 3/8"-16 Nyloc Nuts.

Torque to 40 N•m (30 ft-lbs)

Next insert the J-Bolts so that they hook over the jounce bumper brace (see Figure 4B) and insert into the Upper Bracket slots.

Install the 3/8" Washers and 3/8"-16 Nyloc Nuts.

Torque to 27 N•m (20 ft-lbs)

⚠ PLEASE NOTE: The air bag must have clearance between itself and the surrounding components to prevent any contact when bag is inflated or compressed. Trimming off excess bolt length is required to ensure no contact with the bag or other suspension components can be made once installed.

Once the Upper Bracket is fixed in position, insert the 3/8"-16x3.5" Carriage Bolts through the square holes in the Lower Bracket.

Place the Leaf Spring Clamp Bars over the Carriage Bolts under the leaf springs, secure using the 3/8" Washers and 3/8"-16 Nyloc Nuts.

Torque to 16 N•m (12 ft-lbs)

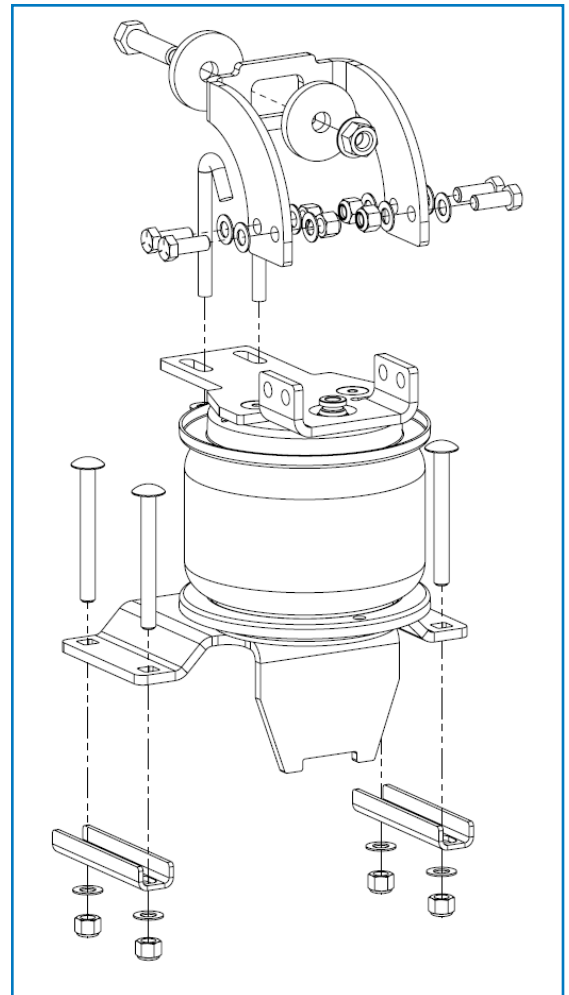

4A



4B

5 INSTALL AIR LINE

PLEASE NOTE: This kit contains push-to-connect fittings; using scissors or wire cutters to cut the nylon airline will distort the line and cause the connection to leak. THE AIRLINE MUST BE CUT OFF SQUARELY WITH THE NYLON HOSE CUTTER PROVIDED IN THIS KIT OR A SHARP UTILITY KNIFE

Provided in air spring kit are two fill valves. The most common place to install is in place of license plate fasteners. Alternatively, two 5/16" holes can be drilled in a convenient location.

Cut air line assembly into two equal lengths with hose cutter.

Install one air line, route the nylon air line to an air spring fitting and cut the hose. Moisten the end of the air line prior to inserting it into the fitting and push it in until it stops. Repeat with the other fill valve.

Secure airlines using the tie-straps, away from moving items and heat sources.

Place a 5/16" nut on the air valve. Leave enough of the inflation valve in front of the nut to extend through the hole, install a flat washer, and 5/16" nut and cap (reference Figure 15 for assembly).

There should be enough valve exposed after installation—approximately 1/2"—to easily apply a pressure gauge or an air chuck.

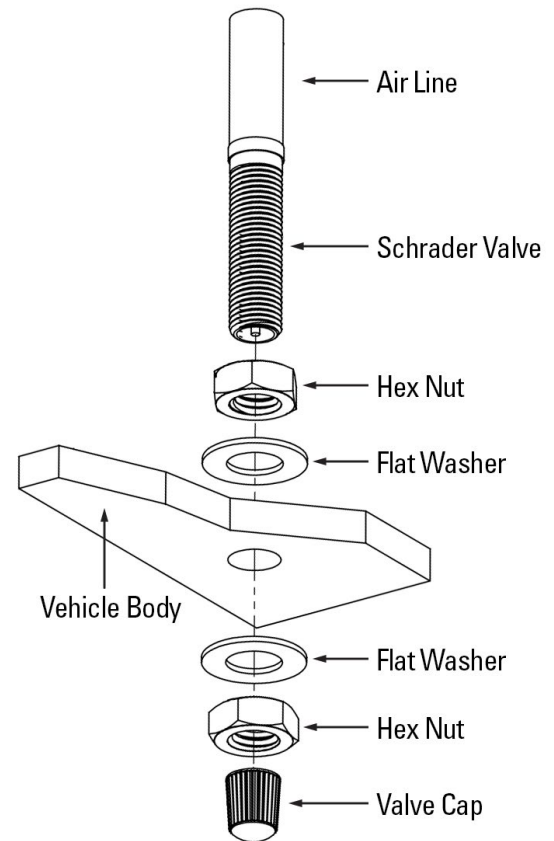

5

6 INSTALL THE HEAT SHIELD:

Bend the tabs on the Heat Shield so there will be the necessary 1/2" dead space between the Heat Shield and the exhaust pipe when attached.

Attach the Heat Shield to the exhaust pipe using two Hose Clamps. Each Hose Clamp holds a tab against the exhaust pipe.

Make sure the Heat Shield is facing toward the Air Spring.

If an in-cab inflation kit is being installed, follow the instructions provided with that kit now.



6

7 CHECK SYSTEM FOR LEAKS

Inflate both air springs to 90 psi and then use a mixture of dish soap and water on all air line connections to detect any air leaks. Large, expanding bubbles indicate a leak (as shown in Figure 7). Repair as necessary and retest.

Inflate air springs to a predetermined value and on following day recheck pressure. If one or both of air springs have lost pressure, an air leak is present. Leak must be repaired, and then retested until no leaks exist.



7

8 AFTER COMPLETING THE INSTALLATION

PLEASE REMEMBER:

Install wheels and torque fasteners to manufacturer's specifications.

Re-torque all fasteners after first 500 miles of driving.

For safe and proper operation, never operate the vehicle under minimum of 10 psi or over maximum of 100 psi in air springs. Staying within pressure limit will ensure maximum air spring life. Failure in doing so may result in a void warranty.

⚠ Do not exceed maximum vehicle payload. Failure to do so may result in failure of the air suspension kit and/or damage to your vehicle.

Thank you again, and congratulations on the installation of the air suspension kit.

OPTIONAL ACCESSORIES

Optional dual needle air gauges are available to monitor pressure in each spring from vehicle cab, as well as a full line of air compressors, air tanks, and solenoids built to work with and control your air spring system.

OPERATING YOUR VEHICLE WITH AIR SUSPENSION

Air springs have minimum and maximum pressure requirements. Never operate your vehicle with less than 10 psi in air spring and never inflate air springs over 100 psi. Damage to air springs will result.

Check air pressure in air springs daily for first couple of days to ensure a leak has not developed. Air springs are designed to maintain the vehicles stock ride height with a load. Do not use the air springs as a means to lift vehicle with no load. This will result in a harsh ride.

SERVICING YOUR VEHICLE WITH AIR SUSPENSION

When lifting the vehicle with a floor jack or hoist on the frame, never allow the air spring to limit the travel of the axle. Try to always jack the vehicle on the axle. Suspending the axle with the air spring limiting the axle travel will damage the air spring and void the air spring warranty.

WARRANTY

The owner's warranty will be void if air springs are run with less than the minimum of 10 psi. See additional warranty for details.

