

Installation Manual

PACBRAKE®

www.pacbrake.com 800.663.0096



HP10338 KIT

*Nissan Titan XD 2WD/4WD**

* See application guide for proper fitment.





KIT CONTENTS

Make sure all the items listed below under "Kit Contents" are provided in your kit before starting the installation.

KIT CONTENTS

A	Air Spring	2
B	Upper Bracket – LH	1
C	Upper Bracket – RH	1
D	Lower Bracket	2
E	Axle Strap	2
F	U-Bolt	2
G	Square U-Bolt	2
H	3/8"-16 x 5" Carriage Bolt	4
I	1/4"-20 Nyloc Nut	2
J	1/4" Flat Washer	4
K	1/4"-20 x 3/4" Head Head Cap Screw	2
L	3/8" Flat Washer	22
M	3/8"-24 x 7/8" Hex Head Cap Screw	8
N	3/8"-16 x 3.75" J-Bolt	2
O	3/8"-16 Nyloc Nut	14
P	M14-1.5 mm x 40 mm Hex Head Cap Screw	2
Q	M14 Flat Washer	2
R	Cable Clamp	2
S	Roll Plate	4
T	90° Brass Air Fitting	2
U	Air Line w/ Schrader Valves - <i>(not shown)</i>	1
V	Tie Straps - <i>(not shown)</i>	6
W	Tube Cutter - <i>(not shown)</i>	1

REQUIRED TOOLS

- Hoist or Floor Jack
- Safety Stands
- Safety Glasses
- Torque Wrench
- Standard Combination Wrenches
- 7/32" Hex Allen Wrench (Socket)
- Ratchet
- Metric & Standard Sockets
- Hose Cutter (included)
- Air Compressor or Compressed Air Source (to fill)
- Spray Bottle with Dish Soap & Water

KIT CONTENTS

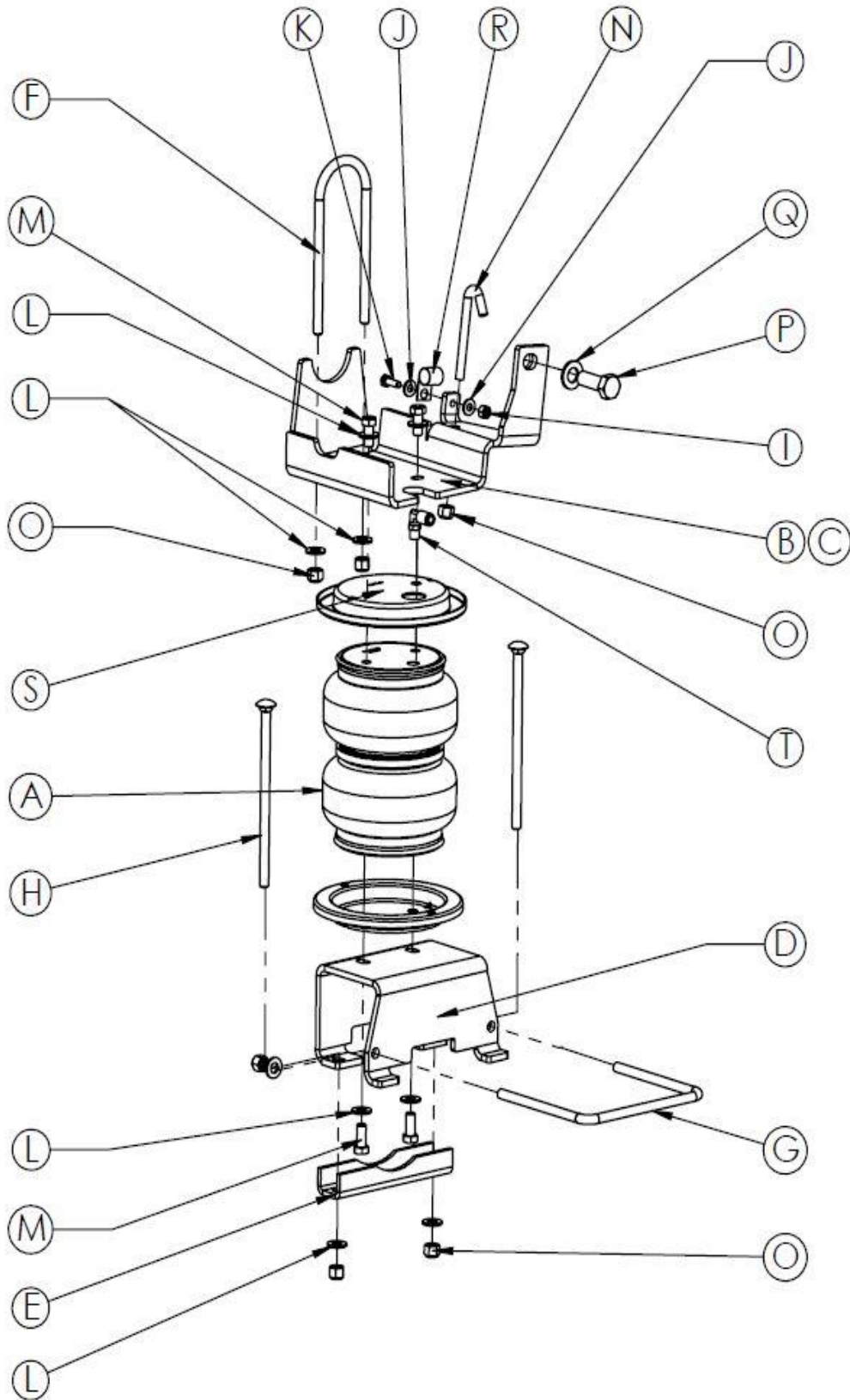

Thank you and congratulations on the purchase of a Pacbrake AMP air suspension kit. Please read the entire manual prior to starting the installation to ensure you can complete it once started.

IMPORTANT

This air suspension kit will not increase the GVWR (Gross Vehicle Weight Rating), as the GVWR is determined by the vehicle manufacturer. Do not exceed the maximum capacity listed by the vehicle manufacturer.

BEFORE YOU START

1. Ensure the application information is correct for the make, model and year of the vehicle you are installing the kit on.
2. Some vehicles are equipped with a rear wheel brake proportioning valve. Check with the manufacturer before installing the air spring kit, as it may affect braking performance.
3. Pacbrake recommends using a good quality anti-seize on all fasteners. This will reduce the chance of corrosion on the fasteners and will help facilitate removal, if required at a later date.

1 MEASURE STOCK RIDE HEIGHT

- Park vehicle on level surface.
- Using measuring tape, measure distance between center of wheel hub and bottom of fender well (this will give you your ride height).
- Note ride height for all four corners.

2 REMOVE REAR WHEELS

- Place wheel chocks in front of and behind both front wheels.
- Raise rear of truck high enough to remove both wheels and attain a comfortable working height.
- Place two jack stands under rear axle.
- Lower vehicle until axle is supported by jack stands.
- Remove rear wheels.

3 DETACH WIRING HARNESS FROM FRAME

- On frame rail from axle rearwards, gently pull out plastic clips securing wiring harness to frame rail on both sides.



4 DETACH VENT TUBE FROM FRAME

- Unbolt bracket securing vent tube to frame and pull it away from frame. Discard bolt.



5 REMOVE 5th-WHEEL FRAME BOLT

- Remove and discard rearmost bolt (19 mm) securing 5th-wheel hitch frame, located on the frame rail, behind jounce bumper strike plate. This bolt is held in place with blue thread locker, an impact wrench and/or penetrating oil may be necessary to remove it.



6 DETACH ABS WIRE FROM BRACKET

- On passenger side axle and upper round crossmember, remove ABS wire from each bracket.

7 BRAKE LINE ADJUSTMENT

- Loosen (do not remove) bolt securing driver side rear brake line to rear axle bracket.
- Rotate brake line counter clockwise as far as possible, retighten bolt. It will only rotate a small amount.

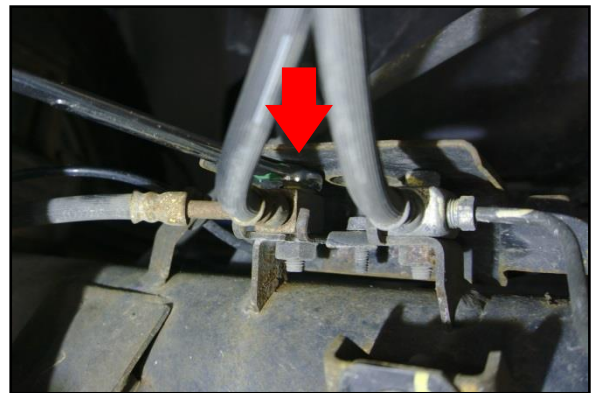

8 J-BOLT INSTALLATION

- Install J-bolt (N) into large hole behind round crossmember, on inside of each frame rail.



9 SQUARE U-BOLT INSTALLATION

- Insert square U-bolt (G) around spring perch, starting towards front of vehicle. U-bolt will sit slightly above nuts on back of hub, squeeze and rotate U-bolt towards rear of vehicle until it snaps into place.
- Ensure U-bolt sits above ABS wire and below leaf spring.

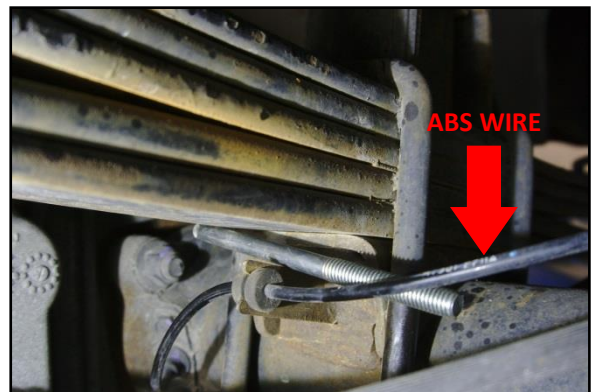

10 POSITION ROUND U-BOLT

- Place round U-bolt (F) around round crossmember above axle (both sides). Ensure wiring does not get pinched.

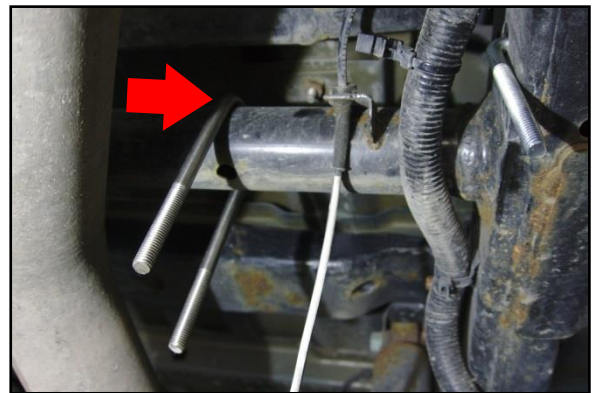

11 ASSEMBLE AIR SPRINGS

- Put a roll plate (S) on top of air spring, making sure each hole lines up.
- Thread 90° air fitting (T) into air spring finger tight, then tighten an additional one and half turns.
- Attach upper brackets (B & C) using two 3/8"-24 x 7/8" hex head cap screws (M) and two 3/8" flat washers (L) per bracket. Torque to 20 ft.-lbs.



- Put both air springs on their side and set remaining two roll plates on air springs, making sure each hole lines up.
- Ensure bent flanges of lower bracket face the same direction that the air fitting is offset relative to mounting bolts. Attach lower brackets (D) using two 3/8"-24 x 7/8" hex head cap screws (M) and two 3/8" flat washers (L) per bracket. Hand tighten only.
- Driver side assembly shown on left, passenger side on right of image.



12 INSTALL ASSEMBLIES

- Set air spring assemblies into position on axle, inboard of leaf spring (lower axle if necessary).
- Raise axle slightly and while doing so, align J-bolts and round U-bolts with holes in upper brackets.
- Ensure ABS wire on passenger side does not get pinched or stretched.
- Apply blue thread locker to M14-1.5mm x 40 mm hex head cap screws (P, 19 mm) and install through upper bracket and existing 5th wheel brace into frame along with M14 flat washers (Q).
- Install 3/8"-16 Nyloc nuts (O) and 3/8" flat washers (L) onto J-bolts and U-bolts.
- Hand-tighten M14 bolt. Torque 3/8" U-bolts and J-bolts to 15 ft.-lbs. in an even pattern. Torque M14 bolt to 77 ft.-lbs.
- Secure lower bracket to already installed square U-bolt with two 3/8" Nyloc nuts (O) and 3/8" flat washers (L) per side.
- Install two 3/8"-16 x 5" carriage bolts (H) in lower bracket and place an axle strap (E) under axle. Secure with two 3/8" Nyloc nuts (O) and 3/8" flat washers (L), but do not tighten.
- Press lower bracket against leaf springs. Ensure tabs of lower bracket sit against outside of leaf spring U-bolts. Hand tighten spring perch square U-bolt evenly. Tighten axle strap evenly, torque to 15 ft.-lbs. Torque spring perch square U-bolt to 15 ft.-lbs. Align air spring bellows. Torque lower air spring hardware to 20 ft.-lbs.

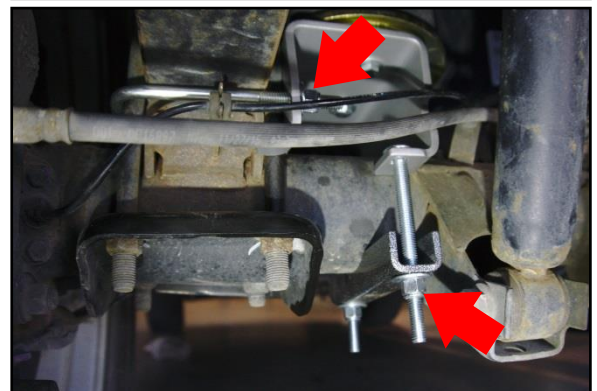

13 DRIVER SIDE WIRING HARNESS

- Install cable clamp (R) around driver’s side wiring harness, facing frame rail. Bolt to upper bracket with ¼”-20 bolt (K), two ¼” flat washers (J) and ¼” Nyloc nut (I) and tighten to 8 ft.-lbs.

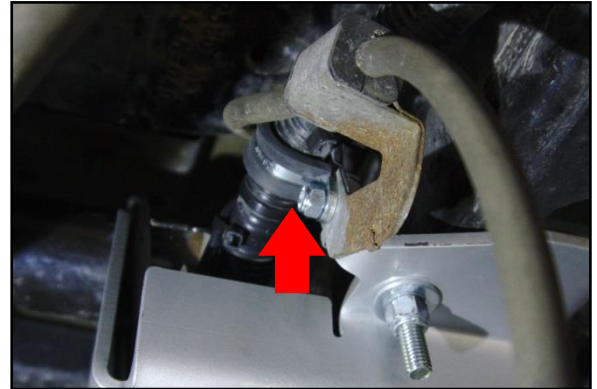

14 PASSENGER WIRING HARNESS, VENT TUBE

- Install cable clamp (R) around passenger side wiring harness and ABS wire (shown). Bolt cable clamp and vent tube bracket to upper bracket with ¼”-20 bolt (K), two ¼” flat washers (J) and ¼” Nyloc nut (I) and tighten.

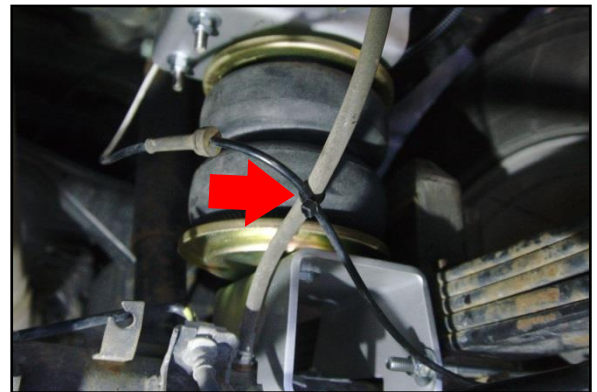

15 SECURE ABS WIRES

- Attach ABS wire on passenger side (removed from bracket in Step 6) with a tie strap to vent tube.
- Repeat for driver side ABS wire.

16 E-BRAKE BRACKET ADJUSTMENT

- Locate emergency brake line brackets on axle (driver and passenger side) and bend them forward slightly so emergency brake like is not touching lower bracket of air spring assemblies.



17 INSTALL AIR LINE

- Provided in air spring kit are two fill valves. The most common place to install is in place of license plate fasteners. Alternatively, two 5/16” holes can be drilled in a convenient location.
- Cut air line assembly (U) into two equal lengths with tube cutter (W).
- Install one air line, route nylon air line to an air spring fitting and cut hose. Moisten end of air line prior to inserting into fitting and push in until it stops. Repeat with other fill valve.
- Secure airlines using tie-straps, away from moving items and heat sources.
- Place 5/16” nut on air valve. Leave enough of inflation valve in front of nut to extend through hole, install flat washer, and 5/16” nut and cap. There should be enough valve exposed after installation—approximately ½”—to easily apply a pressure gauge or an air chuck.
- If an in-cab inflation kit is being installed, follow instructions provided with it.

NOTE: This kit contains push-to-connect fittings, using scissors or wire cutters to cut the nylon airline will distort the line and cause the connection to leak. **THE AIRLINE MUST BE CUT OFF SQUARELY WITH THE NYLON HOSE CUTTER PROVIDED OR A SHARP UTILITY KNIFE**

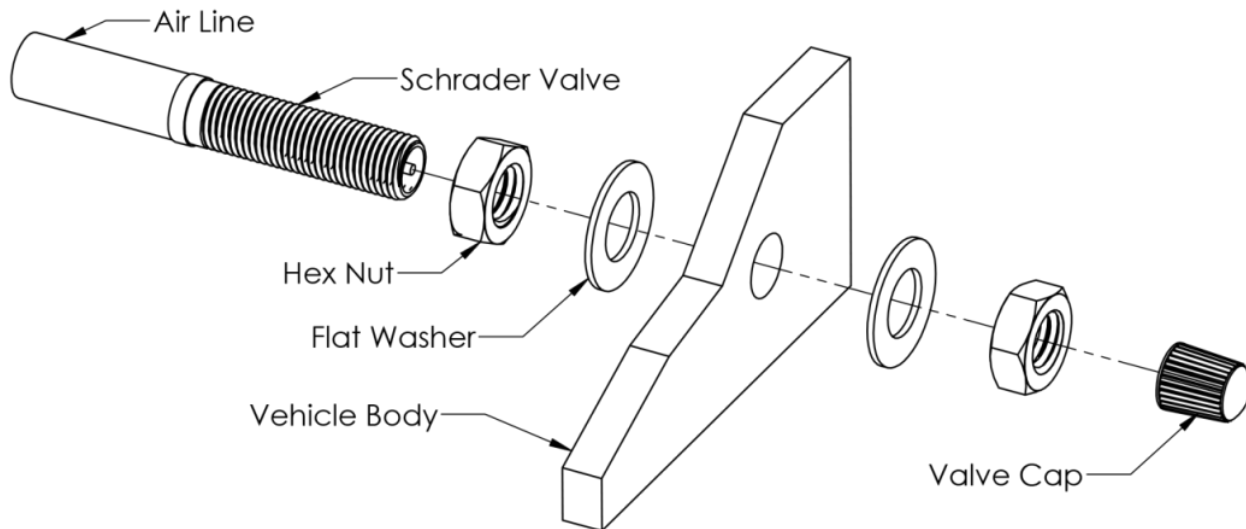

18 CHECK SYSTEM FOR LEAKS

- Inflate both air springs to 90 psi and then use a mixture of dish soap and water on all air line connections to detect any air leaks. Large, expanding bubbles indicate a leak. Repair as necessary and retest.
- Inflate air springs to a predetermined value and on following day recheck pressure. If one or both of air springs have lost pressure, an air leak is present. Leak must be repaired, and then retested until no leaks exist.



19 AFTER INSTALLATION IS COMPLETED, PLEASE REMEMBER:

- Install wheels and torque fasteners to manufacturer's specifications.
- Re-torque all fasteners after first 500 miles of driving.
- For safe and proper operation, never operate the vehicle under minimum of 10 psi or over maximum of 100 psi in air springs. Staying within pressure limit will ensure maximum air spring life. Failure in doing so may result in a void warranty (see Note below).

⚠ Do not exceed maximum vehicle payload. Failure to do so may result in failure of the air suspension kit and/or damage to your vehicle.



OPTIONAL ACCESSORIES

Pacbrake offers an optional dual needle air gauge to monitor pressure in each spring from vehicle cab. Pacbrake offers a full line of air compressors, air tanks, and solenoids to control your air spring system.

OPERATING YOUR VEHICLE WITH PACBRAKE AIR SUSPENSION

Air springs have minimum and maximum pressure requirements. Never operate your vehicle with less than 10 psi in air spring and never inflate air springs over 100 psi. Damage to air springs will result.

Check air pressure in air springs daily for first couple of days to ensure a leak has not developed. Air springs are designed to maintain the vehicles stock ride height with a load. Do not use the air springs as a means to lift vehicle with no load. This will result in a harsh ride.

SERVICING YOUR VEHICLE WITH PACBRAKE AIR SUSPENSION

When lifting the vehicle with a floor jack or hoist on the frame, never allow the air spring to limit the travel of the axle. Try to always jack the vehicle on the axle. Suspending the axle with the air spring limiting the axle travel will damage the air spring and void the air spring warranty.

WARRANTY

To be eligible for warranty, the owner must submit their warranty card or register online within 30 days of the purchase date.

NOTE: *The owner's warranty will be void if air springs are run with less than the minimum of 10 psi.*



CUSTOMER SERVICE HOURS

MONDAY TO FRIDAY FROM 6:00 AM TO 4:30 PM PST

BUSINESS HOURS OF OPERATION

MONDAY TO FRIDAY FROM 7:30 AM TO 4:00 PM PST

CORPORATE HEADQUARTERS / R&D CENTER

19594 96TH AVENUE

SURREY, BRITISH COLUMBIA



ISO 9001
QMI-SAI Global



Pacbrake is a registered trademark of Pacbrake Co.

