

Installation Manual

VERSION
FRANÇAISE

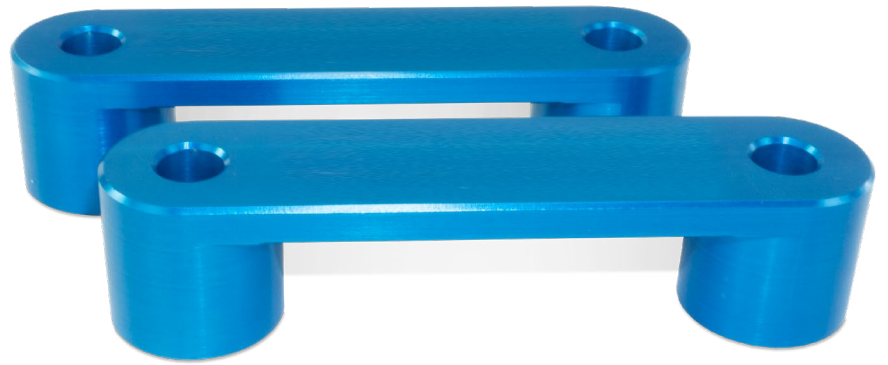

10345 KIT

2" Leveling Kit

Chevrolet / GMC Sierra / Silverado 1500
(2WD/4WD)*

Levels the stance of your vehicle by raising the front end a fixed amount, increasing both the ground and wheel well clearance for the installation of larger wheels.

* See application guide for proper fitment.

L6485_REV5_09.21.2023 ECN 1-2821

Thank you and congratulations on the purchase of a leveling kit. Please read the entire manual prior to starting the installation to ensure you can complete it once started.

KIT LAYOUT

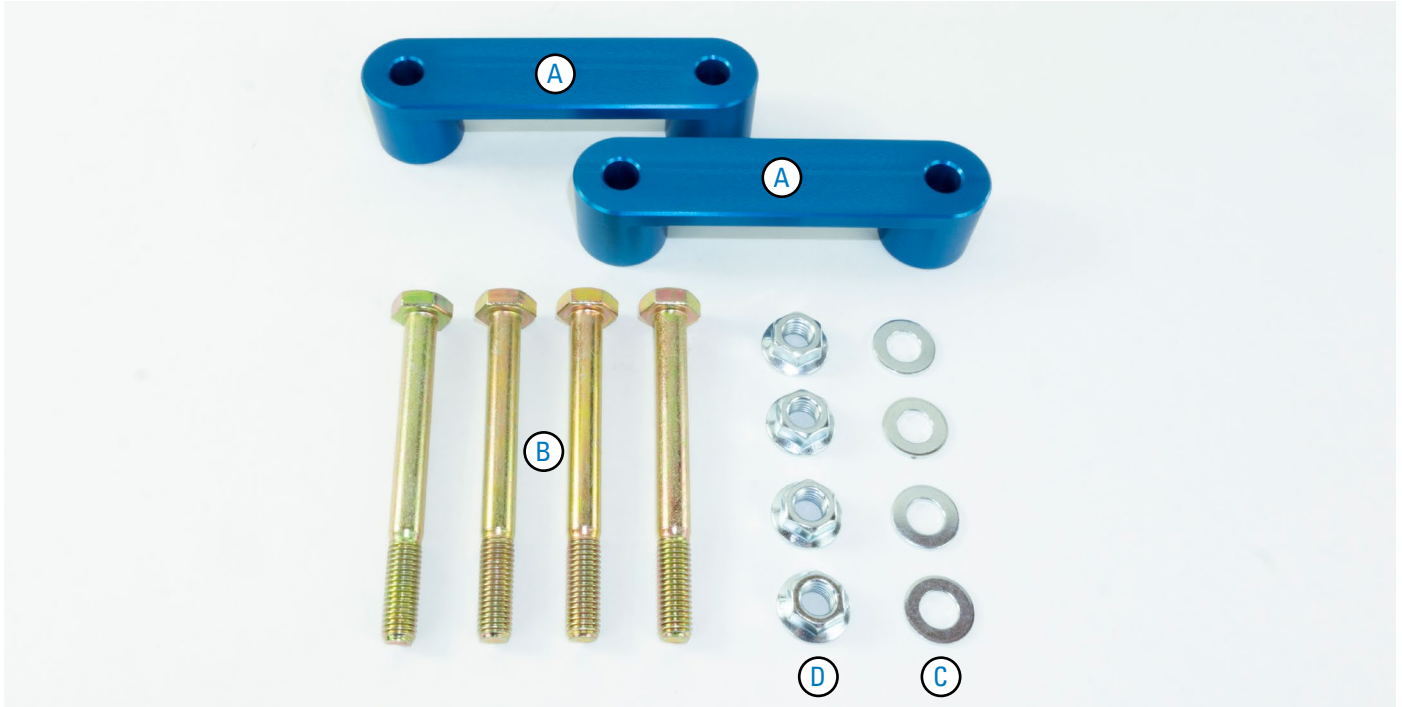

KIT CONTENTS

Please make sure all the items shown in the above kit layout are provided in your kit before starting the installation.

KIT CONTENTS		QTY	PART #
A	Lower Strut Mount Spacer	2	HP1571
B	M10 - 1.5 mm x 95 mm Bolt	4	HP1572
C	M10 Flat Washer	4	HP1573
D	M10 - 1.5 mm Flange Nut	4	HP1457

REQUIRED TOOLS

- Hoist or Floor Jack
- Safety Stands
- Safety Glasses
- Torque Wrench
- Standard Combination Wrenches
- 7/32" Hex Allen Wrench
- 1-1/8" Wrench or Deep Socket
- Metric & Standard
- Sockets Ratchet



WARNING: This product can expose you to the chemical Hexavalent Chromate, which is known to the State of California to cause cancer and birth defects or other reproductive harm. *For more information go to www.P65Warnings.ca.gov*

Please make sure all the items shown in this explosion diagram are provided in your kit before starting the installation.

DRIVER SIDE ASSEMBLY SHOWN:

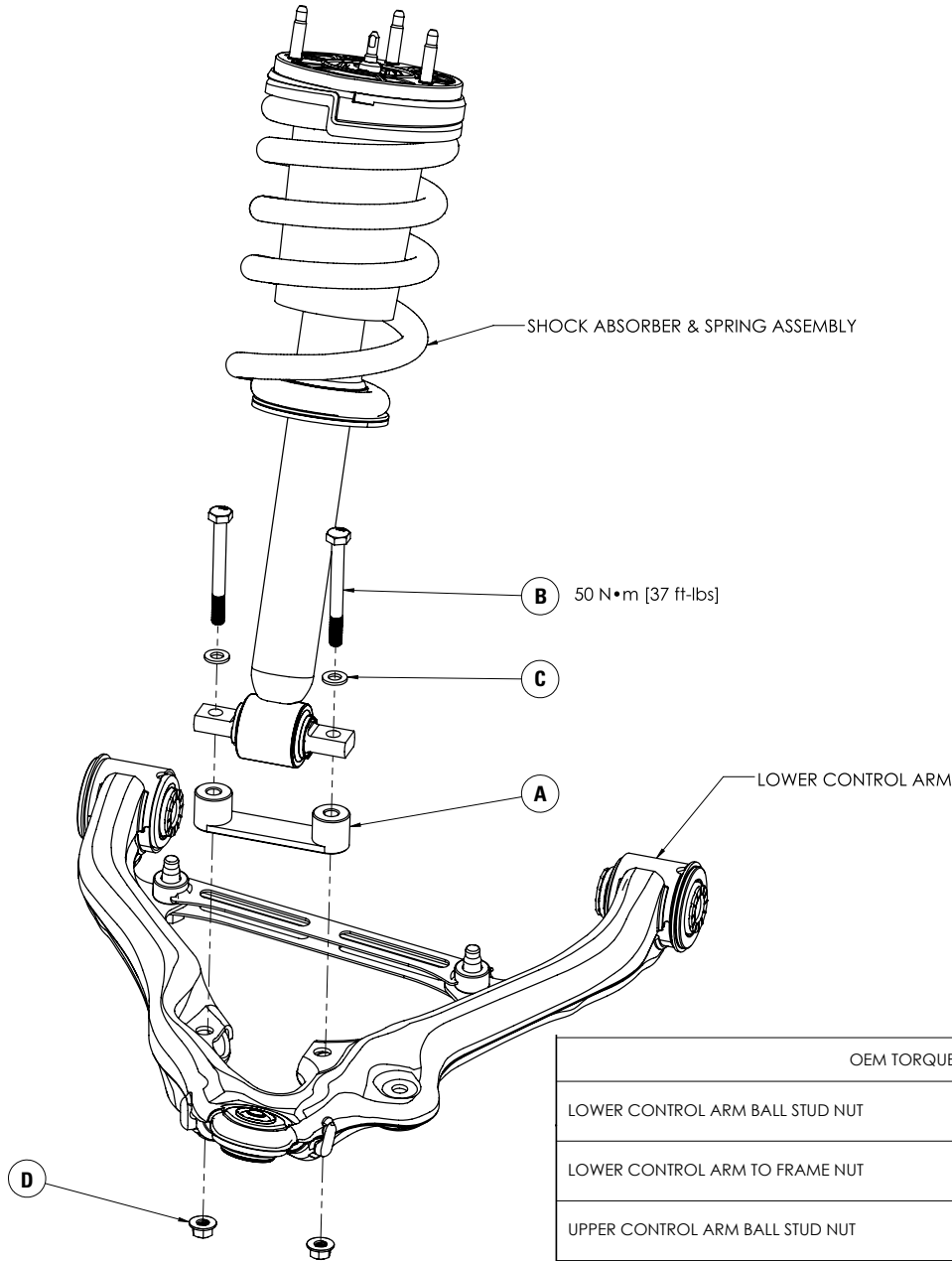

OEM TORQUE SPECIFICATIONS	
LOWER CONTROL ARM BALL STUD NUT	50 N•m [37 ft-lbs] plus an additional 125-135 Degrees
LOWER CONTROL ARM TO FRAME NUT	180 N•m [133 ft-lbs] plus an additional 90-105 Degrees
UPPER CONTROL ARM BALL STUD NUT	35 N•m [26 ft-lbs] plus an additional 85-95 Degrees
UPPER CONTROL ARM TO FRAME NUT	120 N•m [89 ft-lbs] plus an additional 45-60 Degrees
STEERING LINKAGE BALL STUD NUT	35 N•m [26 ft-lbs] plus an additional 85-100 Degrees
SHOCK ABSORBER TO FRAME STUD NUT	58 N•m [43 ft-lbs]
SHOCK ABSORBER TO LOWER CONTROL ARM BOLT	50 N•m [37 ft-lbs]
STABILIZER SHAFT END LINK NUT	100 N•m [74 ft-lbs]
STABILIZER SHAFT CLAMP BOLT	50 N•m [37 ft-lbs]

BEFORE STARTING THE INSTALLATION:

Safety Warning!

Altering the suspension system of your vehicle may cause it to handle differently than it did from the factory. Larger wheel and tire combinations may increase the leverage on the suspension and steering components. This changes the way your vehicles handles and responds to abrupt maneuvers. Operate your vehicle at reduced speeds in all conditions to prevent loss of control. Failure to do so may result in serious injury. It is not recommend to combine the use of suspension lifts, body lifts, or other lifting methods.

Installation Warning!

Use caution when disassembling and reassembling the vehicle. The proceeding instructions are guidelines only, the installer is responsible for ensuring that the vehicle is safe for use after performing the installation. It is recommended to use the factory service manual for the model/year of the vehicle when disassembling and assembling factory related components.

Suspension components that use rubber or urethane bushings should be tightened with the vehicle at normal ride height. This will prevent premature wear or failure of the bushing. Prevent the suspension components from overextension by supporting them with a jack.

PLEASE NOTE: Due to the suspension geometry and vehicle tolerances, the amount of lift is a base figure. **Spacer thickness does not equate to the amount of lift due to the suspension geometry.** For example: a 1" thick spacer may provide a 2" lift. Always measure the vehicle ride height at all 4 corners before and after installation to ensure the results are as expected.

WHEEL ALIGNMENT AND HEADLIGHT ADJUSTMENT

It is necessary to have a proper and professional wheel alignment performed by a certified alignment technician to align the vehicle to factory specifications. After the installation is complete, check to ensure that the vehicle's headlights are aimed properly. If not, a headlight alignment is required.

1 MEASURE STOCK RIDE HEIGHT

Park the vehicle on a level surface.

Using a measuring tape, measure the distance between the center of the wheel hub and the bottom of the fender well (as shown in Figure 1) this will give you your ride height.

Note the ride height for all four corners.

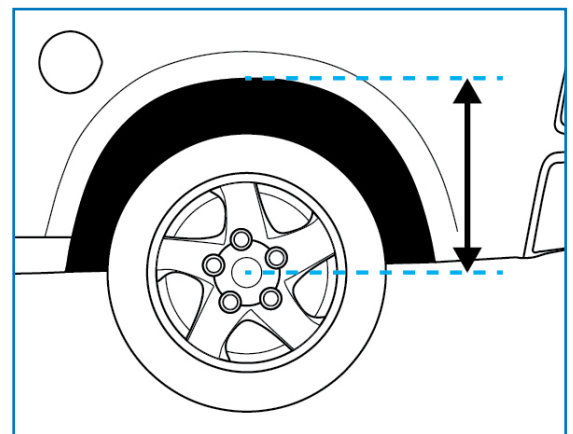

1

2 REMOVE FRONT WHEELS

Place wheel chocks in front of and behind both rear wheels.

Raise front of the truck high enough to remove both wheels and attain a comfortable working height.

Place two jack stands under the vehicles frame.

Lower vehicle until the frame is supported by the jack stands.

Remove front wheels.

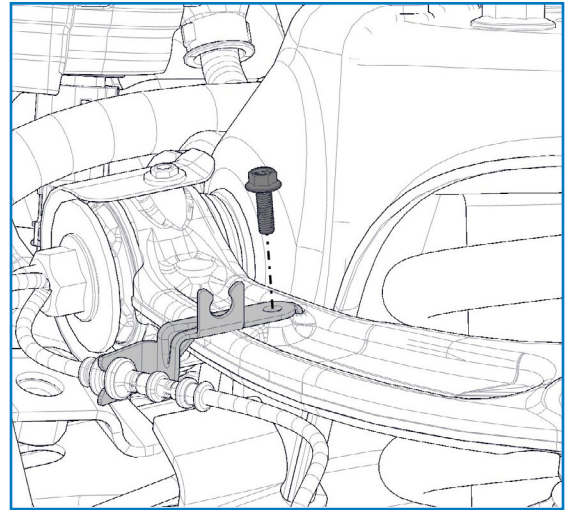

4

3 SUPPORT LOWER CONTROL ARM

Place floor jack under lower control arm, near ball joint.

Jack it up to slightly compress the suspension.

4 REMOVE ABS WIRE BRACKET

Remove bolt securing ABS wire bracket to upper control arm (as shown in Figure 4).

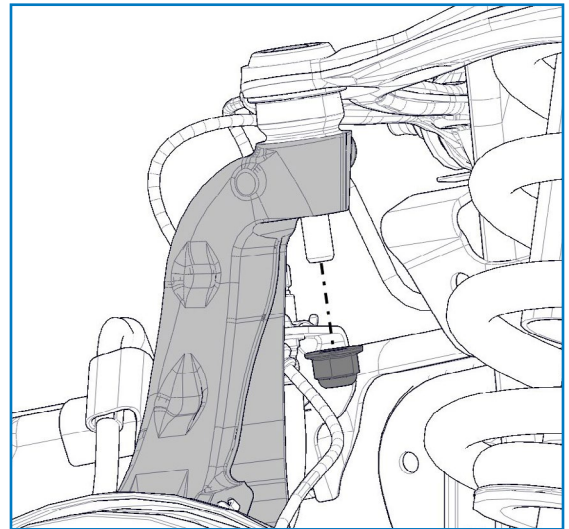

5

5 REMOVE UPPER BALL JOINT NUT

Use hex key to stop ball joint spinning, remove upper ball joint nut (as shown in Figure 5).

Strike upright to dislodge ball joint.

Once nut is removed, lower upright by lowering jack.

6 LOOSEN LOWER CONTROL ARM BOLTS

Mark both lower control arm bolts, to aid in aligning during reassembly in Step 14.

Loosen the two lower control arm bolts 4-5 turns (use Figure 6 as reference) – **do not remove**.

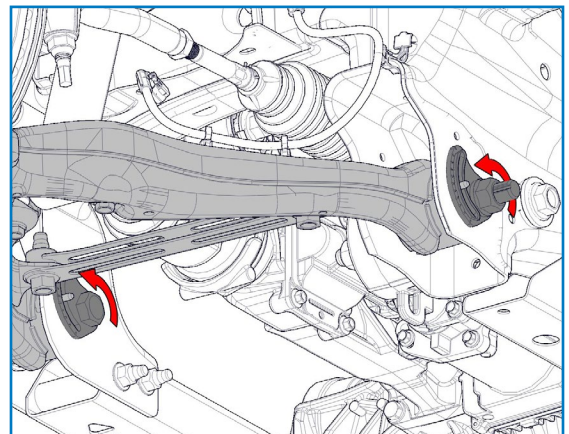

6

7 REMOVE LOWER STRUT MOUNT BOLTS

Remove the two bolts securing lower control arm to lower strut mount cross pin (as shown in Figure 7). Discard bolts.

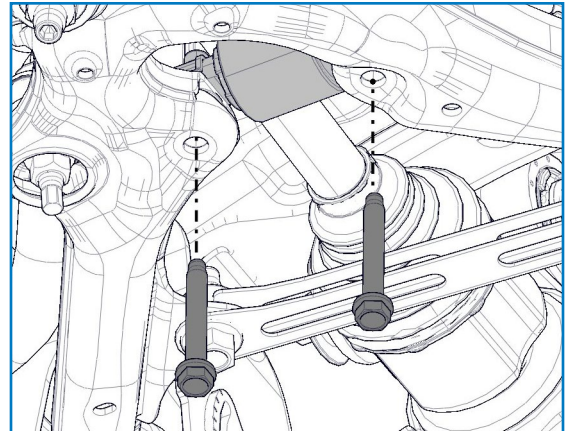

7

8 REMOVE NUT CLIPS

Remove the two nut clips from lower strut mount cross pin (as shown in Figure 8). Discard nut clips.

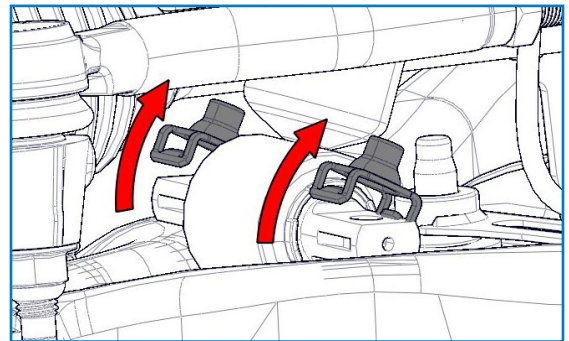

8

9 LOOSEN UPPER STRUT MOUNT NUTS

Loosen the three upper strut mount nuts 4-5 turns (as shown in Figure 9) – **do not remove**.

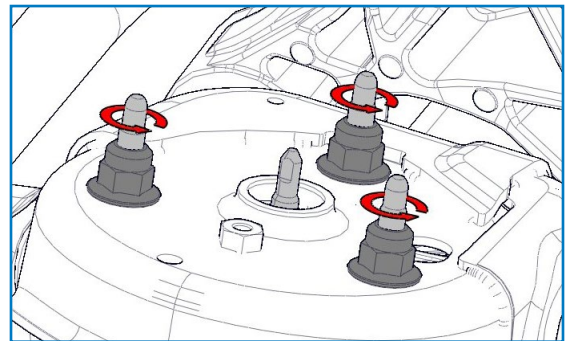

9

10 INSTALL BILLET STRUT SPACER

Insert the billet strut spacer between lower control arm and lower strut mount cross pin (as shown in Figure 10).

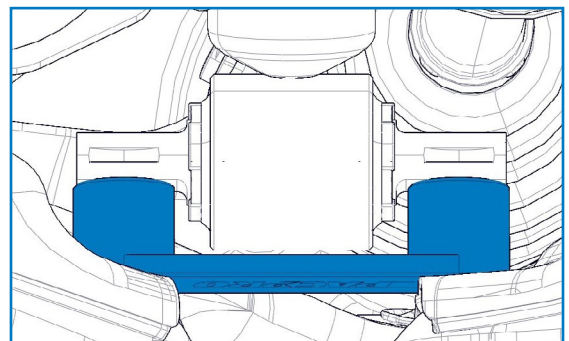

10

11 INSTALL LOWER STRUT MOUNT BOLTS

Shift upright and front axle towards rear of vehicle to insert bolts.

Install the two supplied M10 bolts, with two M10 washers, through lower strut mount cross pin, spacer and lower control arm (as shown in Figure 11 on following page).

Install the two supplied M10 nuts onto the bolts and tighten.

Torque to 58 N•m (43 ft.-lbs).

PLEASE NOTE: Bolt threads MUST point down (towards ground) as shown in Figure 11.

Torque the three upper strut mount nuts to 50 N•m (37 ft.-lbs).

12 CONNECT UPPER BALL JOINT

Insert upper ball joint into upright and thread on factory nut by hand (see Figure 12 on following page).

First torque nut to 35 N•m (26 ft.-lbs).

Mark nut and rotate an additional 85-95 degrees.

13 REATTACH BRAKE LINE

Reinstall bolt to secure brake line bracket to upper control arm.

Torque to 9 N•m (80 in-lbs).

14 LOWER CONTROL ARM BOLTS

Align bolts with marks made in Step 6.

Tighten lower control arm bolts (see Figure 14) – **do not torque**.

⚠ Suspension components that use rubber bushings should be tightened with the vehicle at normal ride height. This will prevent premature wear or failure of the bushing.

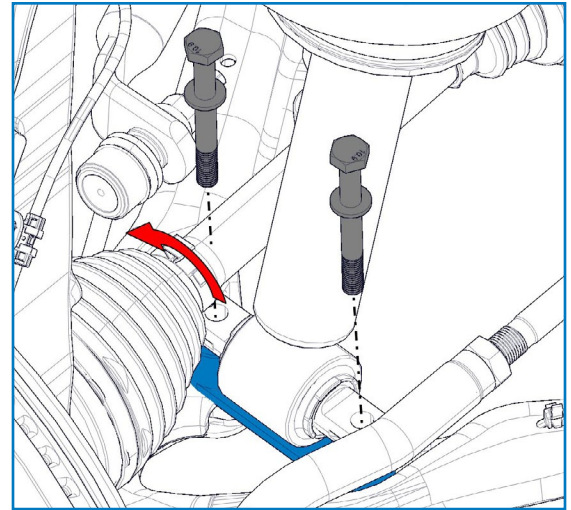

11

15 REPEAT FOR OPPOSITE SIDE

Repeat Steps 3 through 14 for opposite side of the vehicle.

16 REINSTALL WHEELS

Install wheels and torque to factory specification.

Raise vehicle, remove jack stands from under frame and lower vehicle back to ground.

Roll vehicle forward and backwards, and bounce the vehicle up and down several times to stabilize suspension.

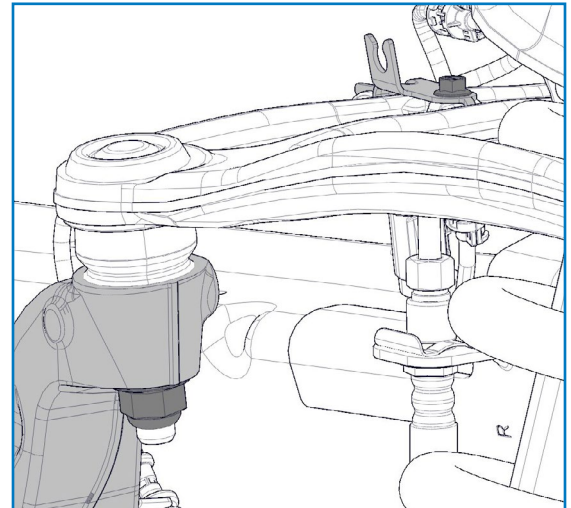

12

17 FULLY TIGHTEN LOWER CONTROL ARM BOLTS

With vehicle on ground, fasteners securing rubber bushings can be fully tightened to factory specifications.

Torque the two lower control arm bolts on each side of the vehicle to 180 N•m (133 ft-lbs) plus an additional 90-105 degrees.

Congratulations!
You have completed the installation

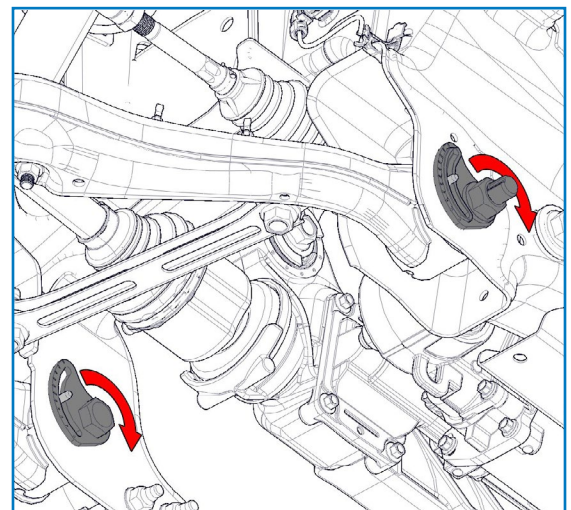

14

POST INSTALLATION WARNING

After the kit installation is complete and the vehicle is on the ground at its normal ride height, roll the vehicle backward and forward to settle the suspension. Tighten all components containing rubber bushings to the specified torque values. Verify adequate tire, wheel, brake line and ABS wire clearance by turning the front wheels completely to the left and then to the right. Ensure brake/ABS lines are not stretched when the suspension is at full droop. Test and inspect steering, brake and suspension components. Vehicle damage may result if the post installation checks are not performed.

VEHICLE HANDLING WARNING

Larger wheel and tire combinations may increase the leverage on the suspension and steering components. Increasing the height of your vehicle increases the likelihood of rollover or loss of control during abrupt manoeuvres, especially at high speeds. Operate your vehicle at reduced speeds in all conditions to prevent loss of control. Failure to do so may result in serious injury.

WHEEL ALIGNMENT & HEADLIGHT ADJUSTMENT

After the kit installation is complete, a professional wheel alignment must be performed by a certified alignment technician to re-align the vehicle to within factory specifications. Additionally, ensure that the vehicles headlights are aimed properly. If not, a headlight alignment is required as well. If not properly aligned it can cause increased tire and suspension component wear.

VEHICLE RE-TORQUE & SAFETY INSPECTION

After the kit installation and adjustments have been completed and within 50 miles of driving, perform a check over of all applicable fasteners and hardware to ensure they are adequately tightened to the specifications given (or as noted in the vehicle's factory service manual).

WARRANTY

To be eligible for warranty, the owner must submit their warranty card or register online within 30 days of the purchase date.

.....