

# Installation Manual

**PH3 POWERHALT**  
AIR INTAKE EMERGENCY SHUT-OFF VALVES *by PACBRAKE*



PH3 MANUAL ACTIVATION (MK-II)

L6495 • ECN 1-2482

800.663.0096

[www.powerhalt.com](http://www.powerhalt.com)



**ATTENTION**

Prior to installation, read through all system requirements.

If you cannot meet certain requirements, or are unsure of your system, contact your dealer or PowerHalt representative and we can work with you to overcome your installation constraints and challenges.

**A PowerHalt Technical Representative can be reached Monday-Friday 6:00-4:30 (PST) at 800.663.0096**

---

**CAUTION**

**Failure to comply with these instructions may result in PRODUCT DAMAGE:**

- Maximum ambient air temperature at valve should not exceed 120°C.
- Maximum air intake temperature at valve should not exceed 175°C.
- Maximum ambient air temperature at controller should not exceed 85°C
- Install valve upstream of air intake flame trap, if present.
- All hoses, adapters, and fittings must be suitable for vibration of engine application.
- Do not mount controller directly on engine, vehicle frame, or other components exhibiting harsh vibration.

**CAUTION**

**Failure to comply with these instructions may result in ENGINE DAMAGE:**

- Confirm overall pipe quality and integrity. Use additional support brackets for long pipe runs and/or excessive vibration applications.
- Flexible hose gaps should be kept to a minimum to avoid hose collapse during valve activation.
- Clear intake plumbing of any shavings and/or debris prior to installation.

**CAUTION**

Failure to comply with these instructions may result in **SYSTEM FAILURE – FALSE TRIPS AND/OR IMPROPER FUNCTION**:

- Install away from bends in engine piping to reduce pressure drop and exposure to vibration resulting from turbulent flow.
- Ensure all intake plumbing gaps are kept to a minimum to avoid system leaks preventing engine shutdown.
- Crankcase breather connections to intake system must be located upstream of shut-off valve.
- If more than one shut-off valve is installed ensure valve activation is simultaneous for all valves.
- Use common battery ground when synchronizing valve activation. If common battery ground is not possible, use relays to create isolation barrier.
- Do NOT remove pins from harness connectors to pass wiring harness through small sized holes.
- Do NOT bend wiring harnesses less than minimum bend radius of 15mm
- Do NOT operate engine with any harness connections disconnected. Doing so could cause system components to fail under extreme operating conditions.
- Ensure power is drawn directly from battery.
- If extending wiring harness lengths, individual runs must not extend beyond 6 meters [20 feet] from controller. Use sealed connections and specified wire type & size as indicated on wiring schematic.
- As this is a safety device, activation testing must be employed at a minimum of once per month to ensure system remains functional and valve is free moving. Daily activations are recommended to ensure proper function of the system.

Thank you for your purchase of a PowerHalt Air Intake Emergency Shut-Off Valve by Pacbrake.  
Please read entire manual before you begin to ensure you can complete installation once started.

**Should you have any issues during installation, please call technical support at 800.663.0096.**

## 1 Valve Installation

Read requirements below to select location and install valve.

- ⚠ If modifying factory engine hose, ensure air path is clear of any interfering wires or protrusions
- ⚠ Install away from elbows where possible. Areas of laminar flow at end of straight pipe sections will reduce pressure drop and exposure to vibration.
- ⚠ Ensure maximum intake temperatures do not exceed 175°C [347°F].
- For applications with intercooler, mounting directly at outlet of intercooler as shown in FIGURE 1-A is recommended to ensure flow is laminar and air temperature is less than specified limit.
- For applications without intercooler, mount in straight section of pipe away from turbocharger as shown in FIGURE 1-B to ensure flow is laminar and air temperature is less than specified limit.
- Ensure 1" clearance from valve to surrounding components. Valve can be rotated as long as it is correctly oriented with respect to air flow.
- Remove appropriate length from intake plumbing to allow for installation of valve. Clear intake plumbing of all shavings and debris.
- If applicable, use beaded pipe to ensure hose retention. See Page 5 for more information on optional PowerHalt Bead Ring Kit.
- Correctly orient valve to flow of air as shown in FIGURE 1-C.
- Fully seat hoses onto valve as shown in FIGURE 1-C.
- Torque provided clamps to 8.5 Nm [75 in-lbf].

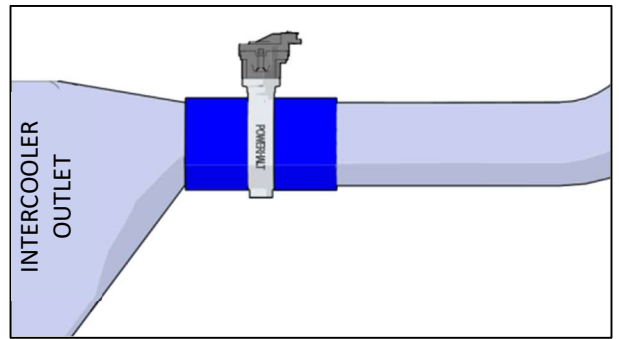

1-A

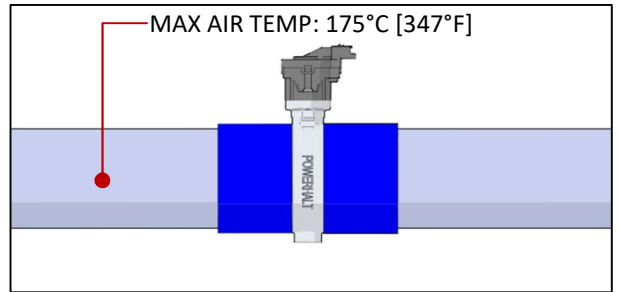

1-B

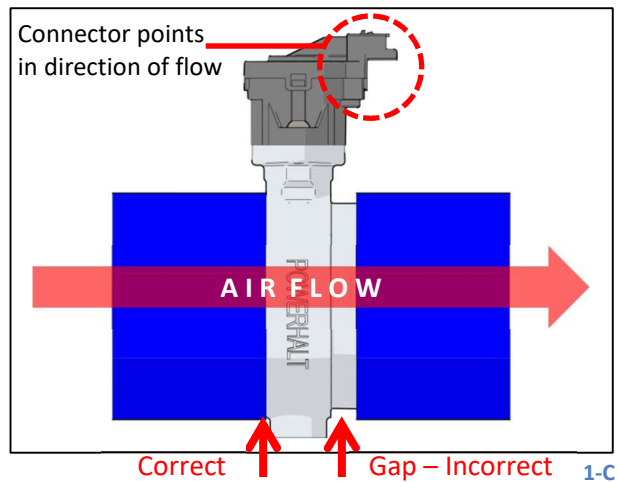

1-C

## 2 Switch Installation

Read requirements below and find suitable location on vehicle dash or engine control panel to install provided switch.

- For Vehicle Applications, switch must be on dash and accessible from ground outside of driver's door.
- Mount switch away from locations exposed to high pressure water and excessive UV exposure.
- Drill 1/2" hole and install switch assembly with toggle cover.

### 3 Controller Installation

Read requirements below and find suitable location for controller. Mount using self-tapping screws or provided tie straps.

- ⚠ Mount controller within vehicle cab underneath dash or within control panel of stationary engines.
- ⚠ Do NOT mount directly on engine, vehicle frame, or other components exhibiting harsh vibration.
  - Mount controller away from locations exposed to high pressure water or steam during engine cleaning.
  - Mount controller away from locations exposed to ambient temperatures above 85°C.
  - Mount controller with connectors exiting from bottom to prevent ingress of standing water.

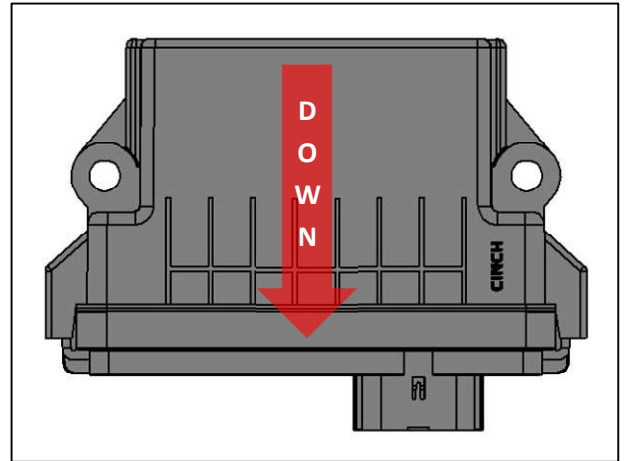

3-A

### 4 Wiring Harness

Read requirements below and follow wiring schematic on following page to make all electrical connections.

- ⚠ Do NOT remove pins from connectors to pass through small sized holes.
- ⚠ Do NOT bend wiring harnesses less than minimum bend radius of 15mm.
- ⚠ Ensure power is drawn directly from battery.
  - Securely latch all connectors. Do NOT disconnect connectors once latched.
  - Allow adequate slack in wiring harness near connections to prevent vibrating components from straining wires.
  - Secure wiring harness away from moving parts or high heat sources with provided tie straps.
  - If extending wiring harness lengths, individual runs must not extend beyond 6 meters [20 feet] from controller. Use sealed connections and specified wire type & size, see Wiring Schematic for details.

### 5 Optional Accessories

Contact PowerHalt Representative to purchase optional accessories below.

#### 5.1 Bead Ring Kit

Creates beaded end on modified engine piping to ensure silicone hoses remain seated.

To install bead ring, notch ends of cut pipe in 3 equal places, attach machined bead ring to pipe, and tack weld at notches as shown in FIGURE 5-A.

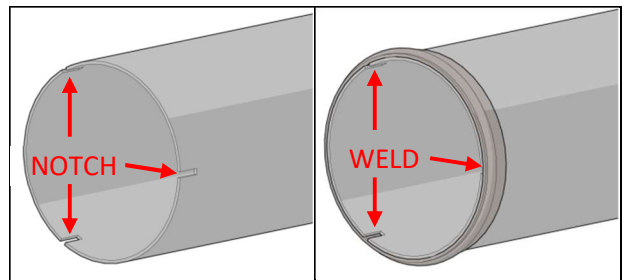

5-A

# Wiring Schematic

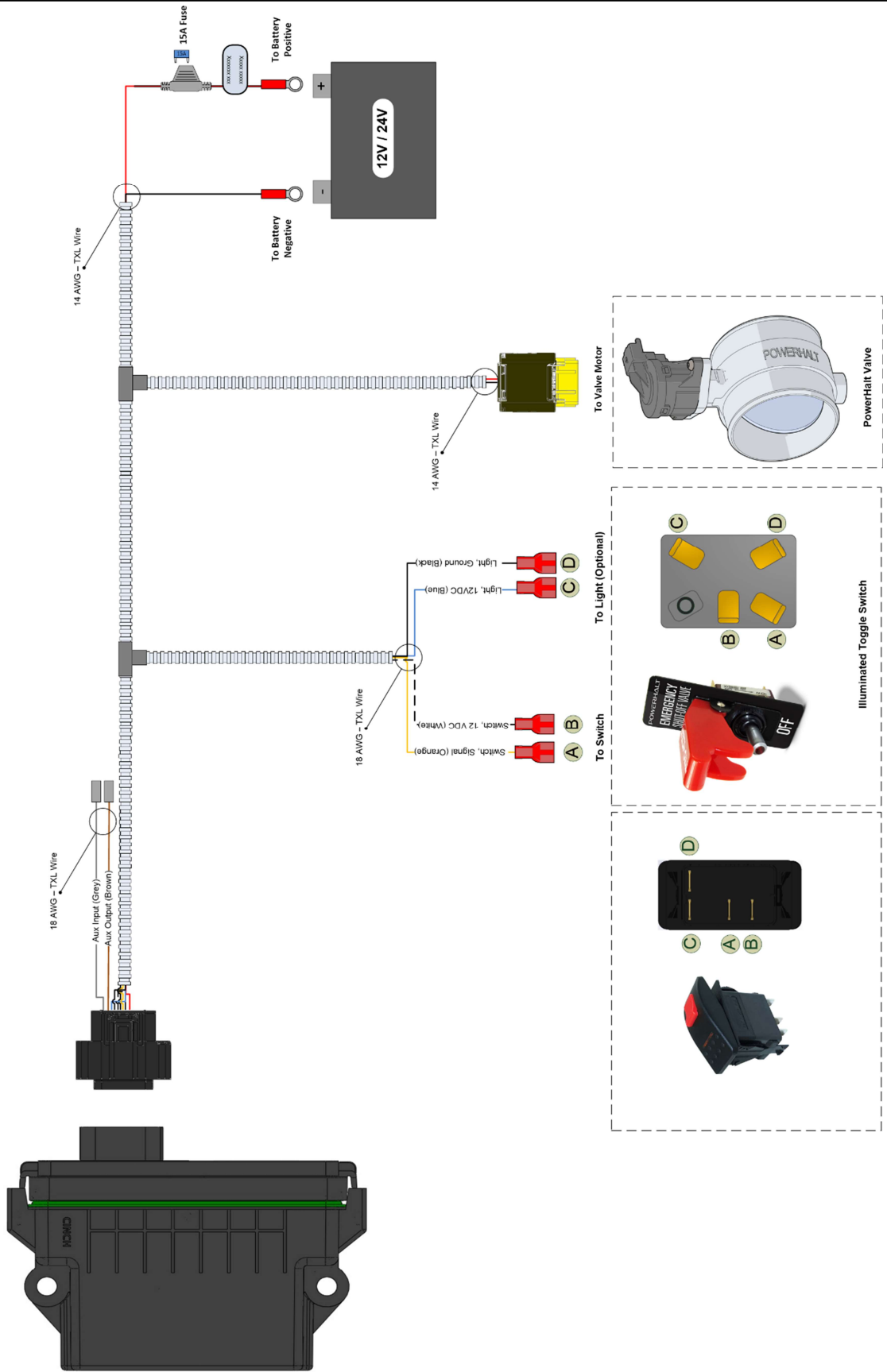

## 6 Additional Features (Optional)

### 6.1 Auxiliary Input Signal

In addition to provided toggle switch, signal from external device can also be used to close valve. Signal specifications:

- Valve will close and remain closed while 6 VDC to 36 VDC is applied
- Valve will open and remain open while less than 6 VDC is applied

To close valve via auxiliary input signal, splice external device into Grey wire (Pin 11 on Controller) and supply specified voltage.

Examples of Auxiliary Input Devices:

- Secondary Toggle Switch
- Overspeed Signal from 3<sup>rd</sup> Party Engine Controller
- Output Signal from adjacent Shut-Off Valve Controller

### 6.2 Auxiliary Output Signal

Output Signal for powering external devices becomes active when valve is closed. Output signal specifications:

- Voltage: 12 VDC
- Max Output Current: 330 mA

To power external device via auxiliary output signal, splice external device into Brown wire (Pin 4 on Controller) and close valve.



Examples of Auxiliary Output applications:

- Illuminate additional indicator light
- Activate external relay
- Synchronize activation of adjacent Shut-Off Valves

**Note:** Auxiliary Output Signal will NOT become active if valve is activated via an Auxiliary Input Signal

### 6.3 Synchronizing PowerHalt Shut-Off Valves

Follow steps below to synchronize valve activation.

-  Connections must be accessible to allow for disconnecting during programming of automatic shut-down function (if applicable).
-  Synchronizing with competitor shut-off valves may require custom designed circuit using Auxiliary Input and Auxiliary Output Signals.

#### 6.3.1 Common Battery Ground for System

-  All PowerHalt valves must be connected to common battery ground – single battery bank for all devices OR separate batteries with connected ground terminal. If ground is not common, valves may fail to synchronize or activate unexpectedly.

1. Install valves as per wiring schematic.

NOTE: If application involves a single engine with multiple intakes, only one toggle switch is necessary for activating all valves. If disconnecting toggle switches, protect exposed harness terminations with heat shrink.

2. Splice Brown Wire (Pin 4 on Controller) and Grey Wire (Pin 11 on Controller) from all valves together as shown in FIGURE 6-A.
3. Prior to running engines, test systems by independently activating each toggle switch and ensuring that each toggle switch closes all valves.

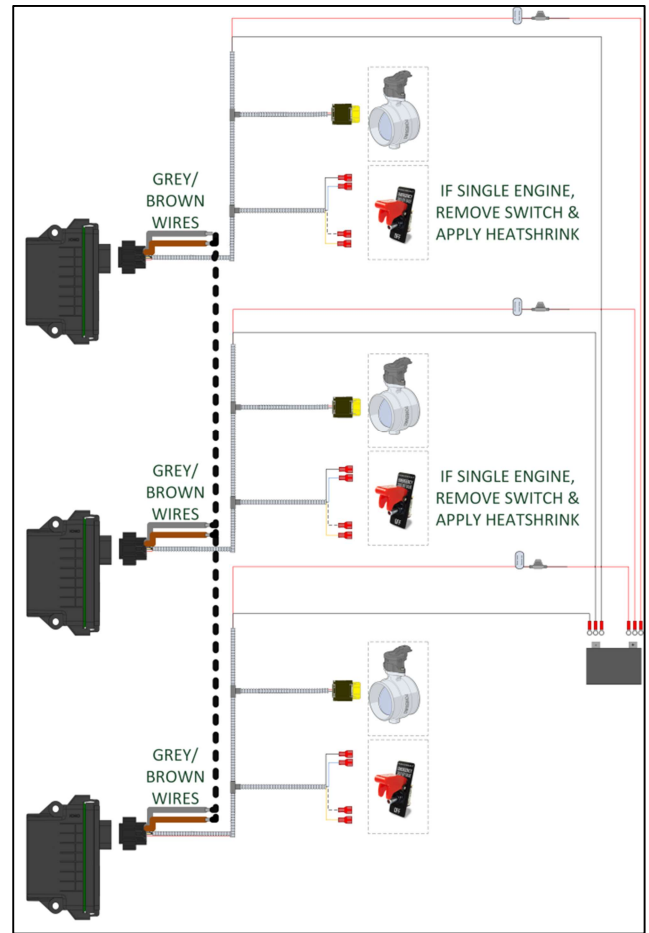

6-A

#### 6.3.2 Different Battery Grounds

-  If systems are connected to different battery grounds, relays must be used to create isolation barrier between systems and ensure safe functionality.

1. Install valves as per wiring schematic.
2. Follow FIGURE 6-B to integrate relays:
  - Splice Brown Wire (Pin 4 on Controller) from each controller into Pin 86 on separate relays.
  - Splice Pin 85 from each relay to each controller's corresponding battery ground.
  - Splice Grey Wire (Pin 11 on Controller) from each controller into Pin 87 on opposite relays.
  - Splice Pin 30 from each relay to each controller's corresponding battery power.
3. Prior to running engines, test systems by independently activating each toggle switch and ensuring that each toggle switch closes all valves.

-  Current output limit for Auxiliary Output Signal (brown wire) must be respected when connecting relays.

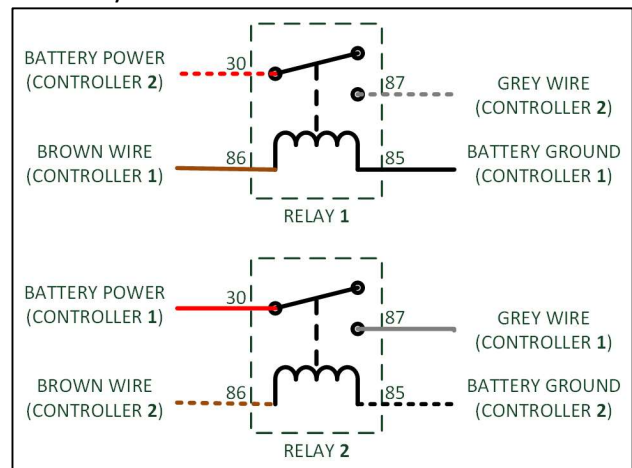

6-B

## 7 System Operation

- The PH3 Air Intake Emergency Shut-Off Valve is an automatically resetting Normally Open valve.
- Activating the toggle switch closes the valve and shuts down the engine.
- The valve remains closed for a minimum of 15 seconds or until toggle switch is released.
- If the switch is held closed, the valve is able to remain closed for a maximum time of 18 minutes, after which point it will begin to de-rate in order to protect itself. The valve will automatically reset itself to the open position once the switch is released.

## 8 Post Installation

Once installation is complete, ensure all steps, schematics, and requirements have been followed before testing your system:

1. Activate and release toggle switch while engine is running.
2. Confirm engine shuts down and the valve is closed.
  - Check all intake plumbing for leaks if engine does not shut down.
3. Confirm valve resets itself 15 seconds after closing.

Valve operation can also be verified with the engine off by observing the position indicator slot on the bottom of the valve. When the valve is open, the slot will be parallel to the direction of air flow. When the valve is closed, the indicator slot will be perpendicular to the direction of air flow. The position indicator does not rotate a complete 90 degrees in the closed position.

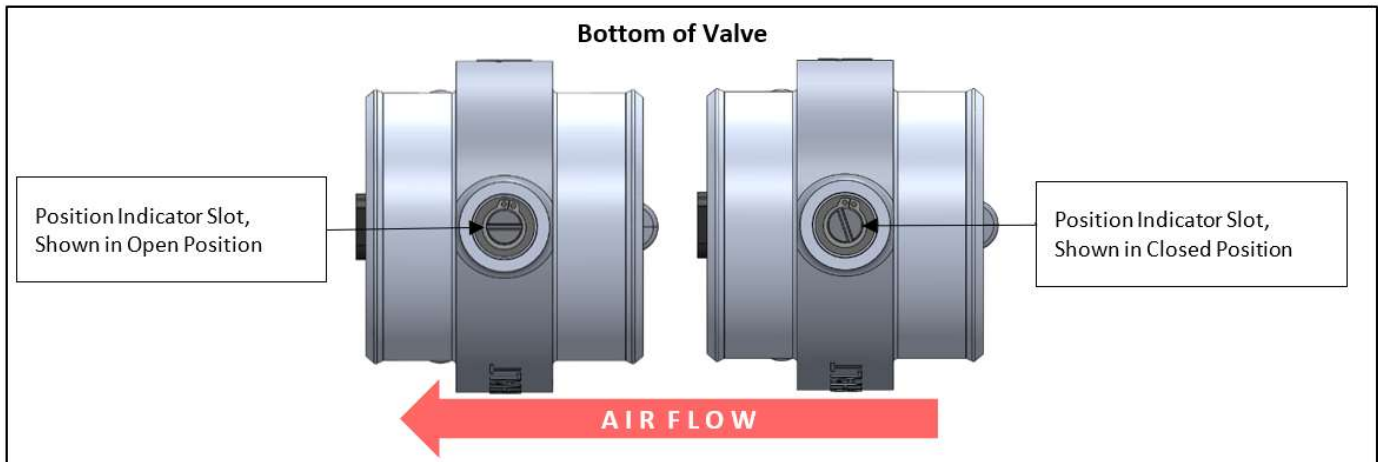

8-A

## 9 Maintenance

To ensure a trouble-free long life of your PowerHalt Shut-Off Valve, a scheduled monthly maintenance procedure is mandatory:

 As this is a safety device, activation testing must be employed at a minimum of once per month to ensure system remains functional and valve is free moving. Daily activations are recommended to ensure proper function of the system.

- Inspect all fasteners, clamps, and support brackets for tightness and required torque
- Inspect all wiring / cable runs for corrosion, vibration wear, and loose connections
- Inspect all hoses for cracks, damage, and leaks
- Inspect controller for damage, dirt, and poor connections



### CUSTOMER SERVICE HOURS

MONDAY TO FRIDAY FROM 6:00 AM TO 4:30 PM PST

### BUSINESS HOURS OF OPERATION

MONDAY TO FRIDAY FROM 7:30 AM TO 4:00 PM PST

### CORPORATE HEADQUARTERS / R&D CENTER

19594 96TH AVENUE  
SURREY, BRITISH COLUMBIA



ISO 9001  
QMI-SAI Global

Patents pending. Pacbrake is a registered trademark of Pacbrake Company. Other trademarks used herein are property of their respective holders.