

Installation Manual



10401-X KIT

Ford F-250 F-350 & F-450 Super Duty (2WD/4WD)*

Eliminate your vehicle's sag, sway and bottoming out while providing added support for an overall smooth and safe ride with this extreme duty air suspension kit. Rated for up to 7500 lbs of load-leveling capacity⁺, this kit is ideally suited for those towing/hauling big loads on a regular basis.

* See application guide for proper fitment.

+ Applications vary. Never exceed manufacturer's recommended Gross Vehicle Weight Rating



WARNING: This product can expose you to the chemical Hexavalent Chromate, which is known to the State of California to cause cancer and birth defects or other reproductive harm. *For more information go to www.P65Warnings.ca.gov*

Thank you and congratulations on the purchase of an air suspension kit. Please read the entire manual prior to starting the installation to ensure you can complete it once started.

IMPORTANT

This air suspension kit will not increase the GVWR (*Gross Vehicle Weight Rating*), as the GVWR is determined by the vehicle manufacturer. **Do not exceed the maximum capacity listed by the vehicle manufacturer.**

PLEASE NOTE: The air bag must have clearance between itself and the surrounding components to prevent any contact when bag is inflated or compressed. Trimming off excess bolt length is also required to ensure no contact with the bag or other suspension components can be made once installed.

Safety Warnings!

- ❗ Serious personal injury or death may result from an air spring failure or accident due to improper installation or air spring pressure operation or maintenance. Please read and abide the instructions, safety recommendations and maintenance suggestions throughout this manual.
- ❗ Inflating an unsecured air spring is dangerous. If it bursts, it could be hurled into the air with explosive force resulting in serious personal injury or death. Never inflate an air spring unless it is secured to the vehicle.
- ❗ Removing and replacing air springs can be dangerous. This is only a job for a qualified service professional. Never perform air spring service procedures without proper training, tools, and equipment.



KIT CONTENTS

Reference the kit explosion diagram on the following page for part assembly.

KIT CONTENTS			QTY	PART #	REQUIRED TOOLS
A	Extreme Duty Air Bag	2	HP10438	<ul style="list-style-type: none"> • Hoist or Floor Jack • Safety Stands • Safety Glasses • Torque Wrench • Standard Combination Wrenches • 1-1/8" Wrench or Deep Socket • Ratchet • Metric & Standard Sockets • Hose Cutter (included) or Sharp Utility Knife • Pipe Thread Sealant • Spray Bottle with Dish Soap/Water • Air Compressor/Compressed Air Source (to test/fill air springs) 	
B	Roll Plate	4	HP10069		
C	Upper Bracket	2	HP1485		
D	Lower Axle Bracket	2	HP1745		
E	Lower Bag Bracket	2	HP1672		
F	Lock Plate, Hex Head	4	HP1748		
G	Spacer, Lower Bracket	4	HP1749		
H	Axle Strap	2	HP0009		
I	Bolt, 3/8" - 24 X 7/8" Hex Head	4	HP1002		
J	Bolt, 3/8" - 24 X 3/4" Countersunk	4	HP1008		
K	Bolt, 3/8" - 16 X 1.5" Hex Head	8	HP1646		
L	Bolt, 3/8" - 16 X 4" Carriage	4	HP1728		
M	Bolt, M10 X 1.5 X 35mm Hex Head	4	HP1134		
N	U-Bolt, 7" X 5.5" Square	2	HP1486		
O	Washer, 3/8" Flat	24	C18006		
P	Washer, 3/8" Split Lock	4	C18007		
Q	Nut, 3/8" Nylon Lock	16	HP1000		
R	Nut, M10 X 1.5mm Clip-On Barrel	4	HP1421		
S	Heat Shield	2	HP0012		
T	Worm Gear Ring Clamp	2	HP1001		
U	Worm Gear Ring Clamp	2	HP1377		
V	Fitting, Brass Straight	2	HP1385		
W	Brake Line Relocation Bracket	1	HP1858		
X	5/8" Adel Clamp	1	HP1006		
Y	Bolt, 5/16" - 18 X 1" Flange	1	C11819		
Z	Nut, 5/16" Nylon Lock	1	C11943		
AA	Washer, 5/16" Flat	1	C11944		
BB	Nut, 3/8" Serrated Flange	1	HP1338		

Please make sure all the items shown in this explosion diagram are provided in your kit before starting the installation.

DRIVER SIDE ASSEMBLY SHOWN:

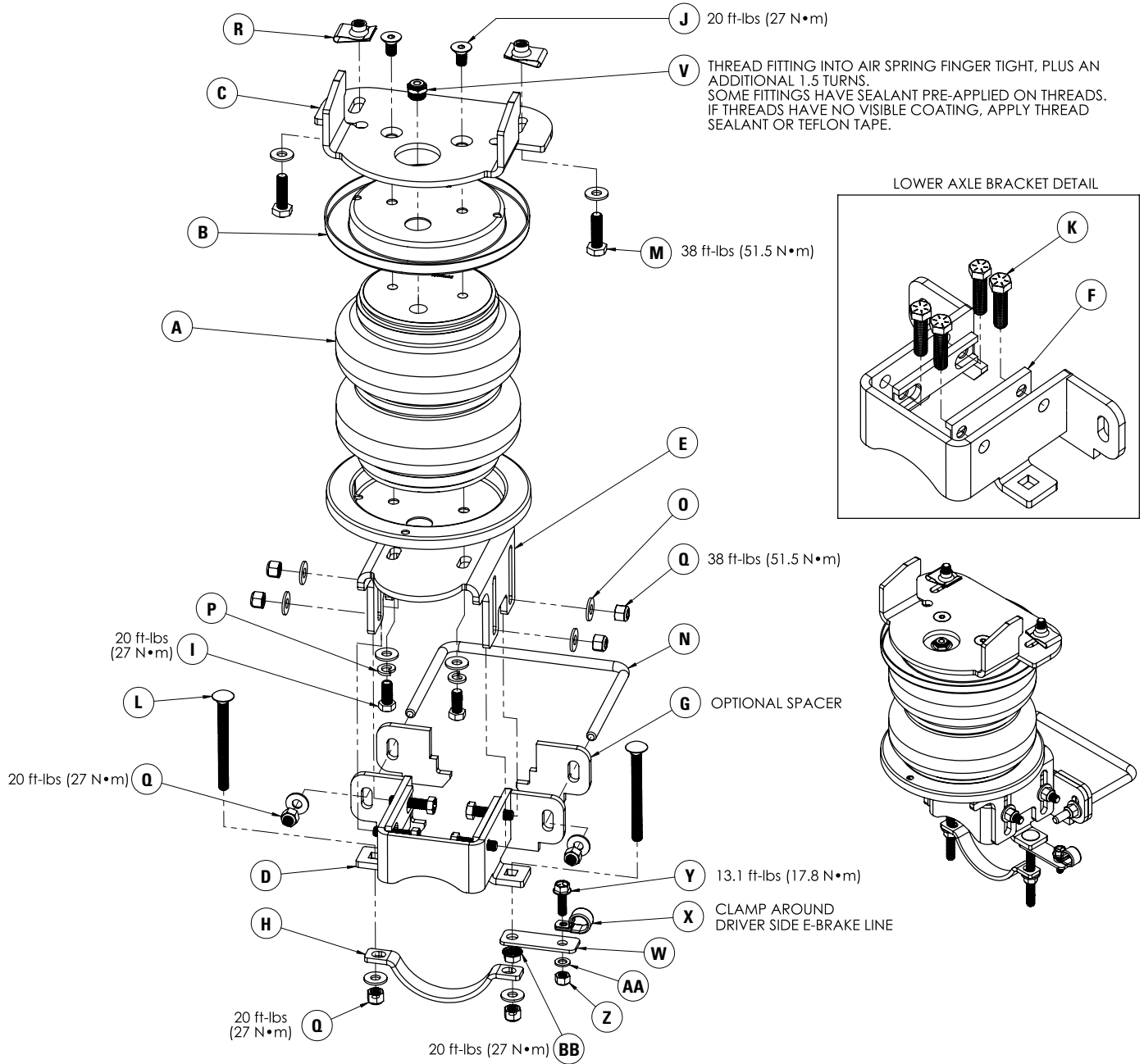

BEFORE STARTING THE INSTALLATION:

1. Ensure the application information is correct for the make, model and year of the vehicle you are installing the kit on.
2. Some vehicles are equipped with a rear wheel brake proportioning valve. Check with the manufacturer before installing the air spring kit, as it may affect braking performance.
3. It is recommended to use a good quality anti-seize on all fasteners. This will reduce the chance of corrosion on the fasteners and will help facilitate removal, if required at a later date.

PLEASE NOTE:

This kit contains push-to-connect fittings; using scissors or wire cutters to cut the nylon airline will distort the line and cause the connection to leak. THE AIRLINE MUST BE CUT OFF SQUARELY WITH THE NYLON HOSE CUTTER PROVIDED IN THIS KIT OR A SHARP UTILITY KNIFE.

1 REMOVE REAR WHEELS

Place wheel chocks in front of and behind both front wheels.

Raise the rear of the truck high enough to remove both wheels and attain a comfortable working height.

Place two jack stands under rear axle (see Figure 1).

Lower the vehicle until the axle is supported by the jack stands.

Remove rear wheels.

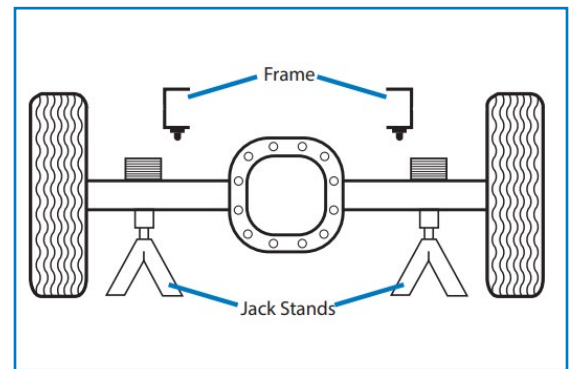

1

2 PRE-ASSEMBLE AIR SPRING

Install the 3/8" NPT fitting into the port on the top of the air spring (see Figure 2).

Tighten the fitting finger tight plus an additional 1.5 turns. The use of Teflon tape or thread sealant is recommended.

Set a roll plate on top of the air spring.

Insert two M10 x 1.5 x 35 mm hex bolts and two 3/8" flat washers into the slotted holes of the upper bracket (as shown in Figure 3) and place the bracket on top of the roll plate.

Ensure all holes are aligned and install two 3/8" - 24 X 3/4" countersunk bolts.

Torque countersunk bolts to 27 N•m (20 ft-lbs).

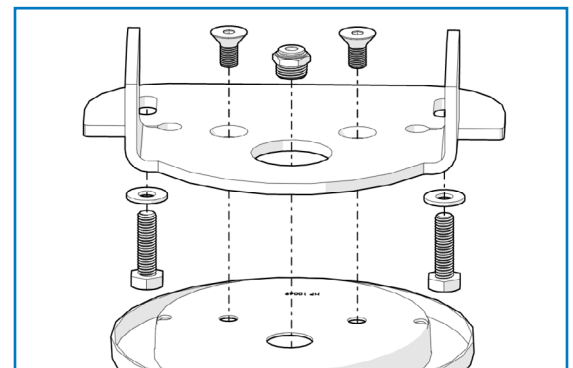

2

3 PRE-ASSEMBLE LOWER BRACKET

Assemble the lower axle bracket and lower air spring bracket (as shown in Figure 3).

Place two bolt head lock plates in position with flat sides against the inside of the lower bracket.

Align holes and insert four 3/8" – 16 x 1.5" hex bolts through the lock plates and the lower brackets.

Attach four 3/8" flat washers and four 3/8" nylon lock nuts onto the ends of the bolts.

Align hex heads of the bolts as per the image callout. Hand-tighten nuts so that the bolt heads fall within the machined grooves of the lock plate, preventing rotation.

Snug up the bolts enough to prevent the brackets from freely sliding but still allow for adjustment when a small amount of force is applied.

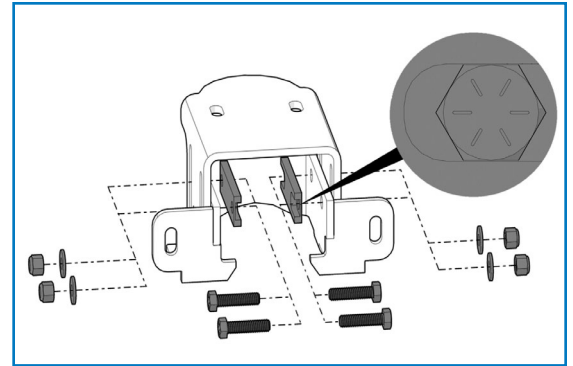

3

4 REMOVE JOUNCE BUMPER

Unbolt and remove the jounce bumper assembly from under the frame on both sides of the vehicle (as shown in Figure 4).

PLEASE NOTE: It may be necessary to use an impact tool to remove the nuts.

Remove the OEM bolts and retainer clips that attached the jounce bumper assembly to the frame and discard as they will not be reused in this installation.

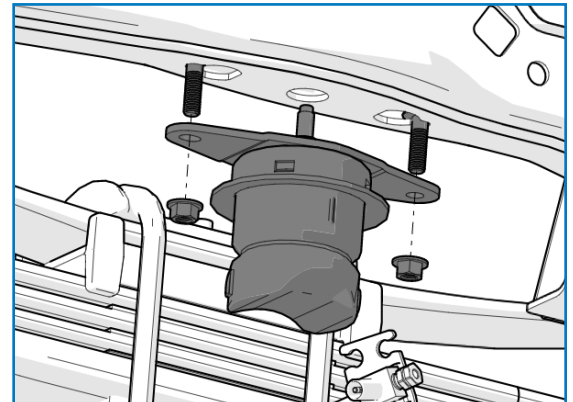

4

5 PLACE LOWER BRACKET

Twist the lower bracket assembly into position on the axle (as shown in Figure 5) with the axle bracket sitting on the axle and the air spring bracket positioned above the lift block (if equipped).

PLEASE NOTE: An ABS line on the driver's side may need to be unclipped from the fixed brake line bracket to prevent pinching between the axle and bracket.

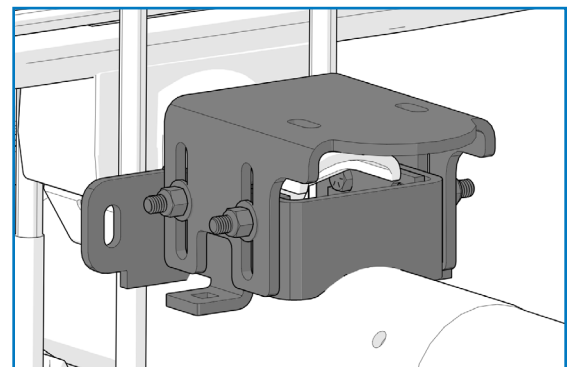

5

6 CHECK BRAKE LINES FOR INTERFERENCE

There may be interference between the lower bracket of the kit and the brake line (as seen in Figure 6).

Using caution not to pull or strain the brake lines: carefully bend the brake line bracket away from the lower air spring brackets (as shown with an arrow in Figure 6) to provide a gap between the two.

It may be necessary to unbolt the retaining bracket securing the brake line under the leaf pack to adequately bend the bracket without stressing the hard lines.

It is recommended to further protect the brake lines by wrapping the line in the convoluted conduit (plastic sleeve), provided in this kit, to further reduce the risk of wear by friction or rubbing.

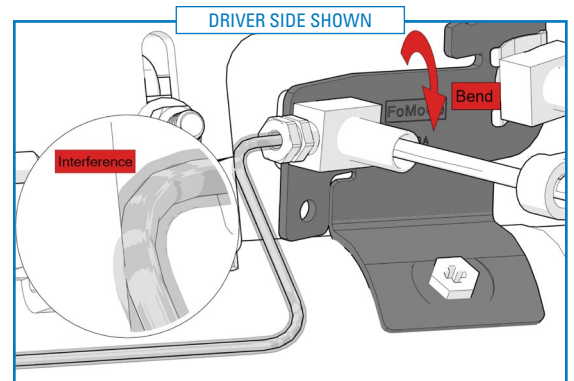

10

7 INSTALL CLIP-ON BARREL NUTS

Install the clip-on barrel nuts in the holes previously occupied by the jounce bumper hardware.

Orient the nuts (as shown in Figure 7) with the threaded portion towards the inside of the frame and the open ends of the clips facing away from each other.

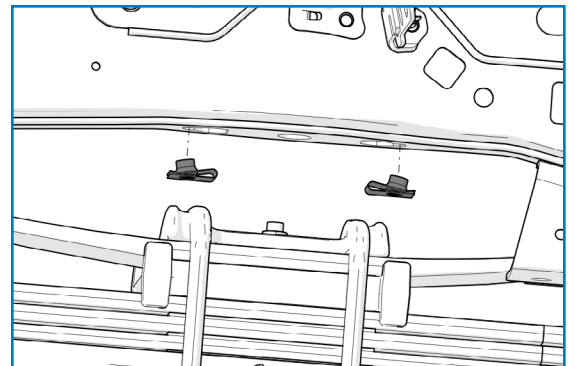

7

8 INSTALL AIR SPRING ASSEMBLY

PLEASE NOTE: It may be necessary to raise the frame of the truck a few inches to allow more clearance to install the air spring assemblies.

Set the air spring assembly in position (as shown in Figure 8).

Secure the upper bracket to the frame by threading the M10 x 1.5" x 35mm hex bolts and two 3/8" flat washers into the previously installed barrel nuts.

Ensure the upper bracket sits flat against the bottom of the frame with the two vertical flanges resting against the inner surface of the frame.

Torque the hex bolts to 51.5 N•m (38 ft-lbs).

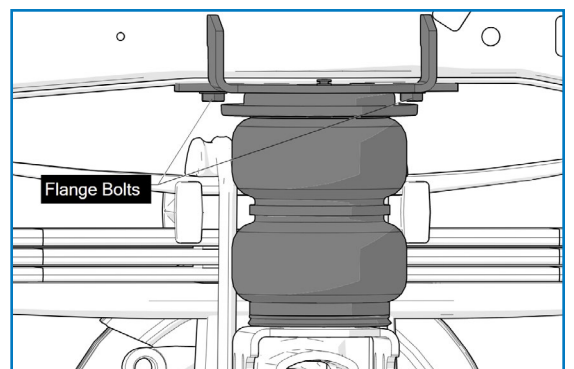

8

9 ATTACH AIR SPRING LOWER BRACKET

Raise the frame of the truck a few inches to provide more clearance to attach the air spring assemblies.

Pull the lower bracket assembly to extend it as much as possible.

Insert a roll plate between the air spring and the air spring bracket (as shown in Figure 9A).

Align the holes in the bracket, roll plate and air spring, and secure the assembly with two 3/8" – 24 x 7/8" hex bolts, two 3/8" flat washers and two 3/8" split lock washers as shown.

Hold the lower axle bracket roughly in its final installed position and adjust the two bolts in the slotted holes of the lower air bag bracket to align the air spring as vertical as possible (see Figure 9B for reference).

When positioned, tighten the two hex head bolts to 27 N•m (20 ft-lbs).

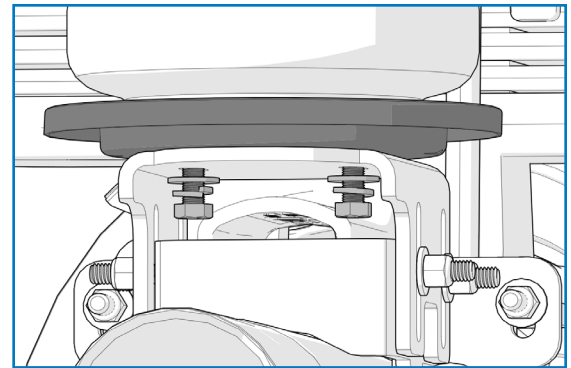

9A

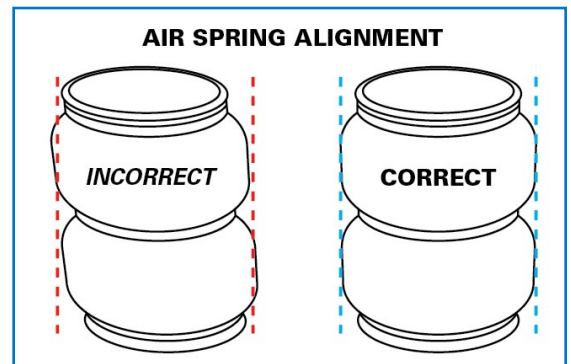

9B

10 CHECK LOWER BRACKET FLANGES FOR CONTACT

Ensure lower axle bracket is fully resting on the vehicle axle and push the air spring assembly towards the leaf pack.

At its furthest position, observe bracket flanges for contact with the leaf spring U-bolts.

! IMPORTANT INSTALL NOTE:

- If the lower axle bracket is in contact with the leaf spring U-bolts (as shown in Figure 10A) spacers are **NOT REQUIRED**.
Omit Step 11 and proceed to Step 12 on the following page.
- If there is **ANY GAP** between the lower axle bracket and the leaf spring U-bolts (as shown in Figure 10B), **spacers must be installed as per Step 11 on the following page.**

PLEASE NOTE: In some vehicles, the lower bracket may contact the E-brake hanger on the driver's side when the spacers are installed. If contact occurs, remove the E-brake hanger from the vehicle. A relocation bracket will be installed in a later step.

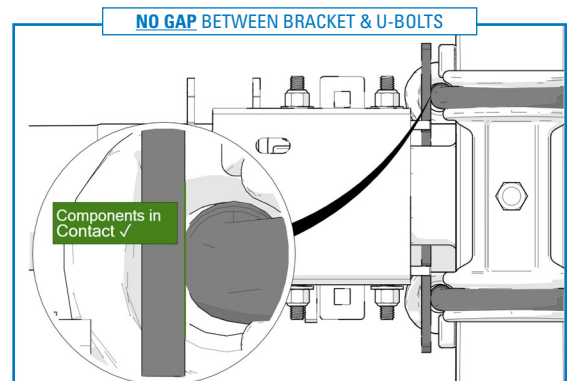

10A

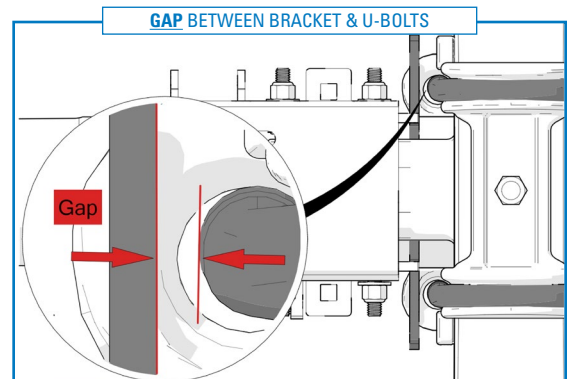

10B

11 INSTALL SPACERS

Place the two spacers provided in between the lower bracket flanges and leaf pack U-bolts (as shown in Figure 11).

Align spacers with flanges, ensuring edges and slot holes align.

Hold spacers in position while completing the next step.

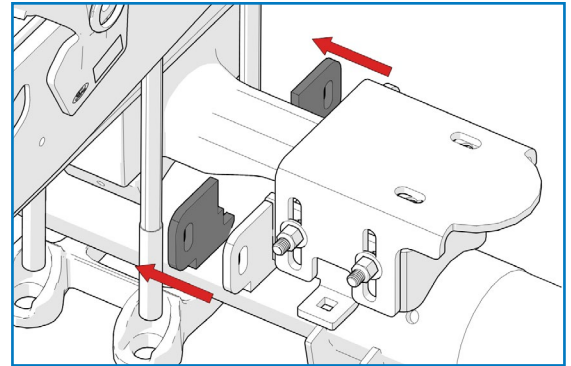

11

12 SECURE U-BOLT

Insert the square U-bolt around the leaf pack and through the slot holes on the spacers (if present) and lower axle bracket flanges.

PLEASE NOTE: Figure 12 shows installation when spacers are present

Secure the U-bolt using two 3/8" flat washers & two 3/8" nylon lock nuts.

Do not fully tighten yet.

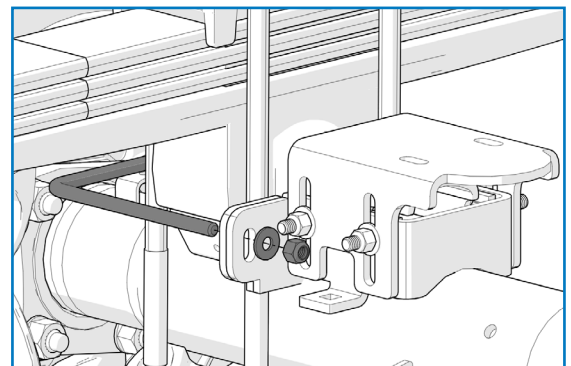

12

13 ATTACH AXLE STRAP

Insert a 3/8" – 16 x 5" carriage bolt into each of the square holes on the lower axle bracket.

If the E-Brake hanger was removed in Step 10, install the brake line relocation bracket and secure with a 3/8" serrated flange nut (as shown in Figure 13).

Torque the flange nut to 27 N•m (20 ft-lbs).

Attach the axle strap to the carriage bolts (as shown in Figure 13) using two 3/8" flat washers and two 3/8" nylon lock nuts.

Tighten the two nylon lock nuts on the axle strap to 27 N•m (20 ft-lbs).

Tighten the two nylon lock nuts securing the U-Bolt to 27 N•m (20 ft-lbs).

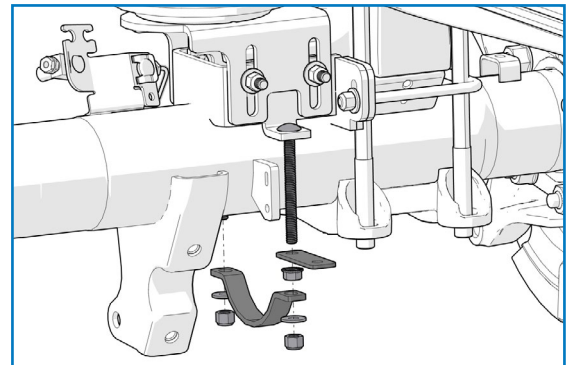

13

14 Secure the E-brake line to the relocation bracket using the 5/8" adel clamp, 5/16" – 18 x 1" flange bolt, 5/16" washer & 5/16" nylon lock nut.

Torque flange nut to 17.8 N•m (13.1 ft-lbs).

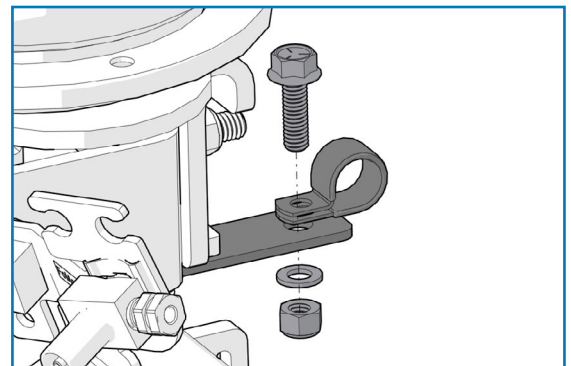

14

15 SET AIR SPRING BRACKET HEIGHT

For vehicles **WITH** a lift block:

Lower the air spring bracket until it just touches the lift block (shown in Figure 15A).

Torque the four hex bolts to 51.5 N•m (38 ft-lbs) to lock this height.

For vehicles **WITHOUT** a lift block:

Lower the air spring bracket to the lowest possible position (shown in Figure 15B) that does not result in interference with other components.

Torque the four hex bolts to 51.5 N•m (38 ft-lbs).

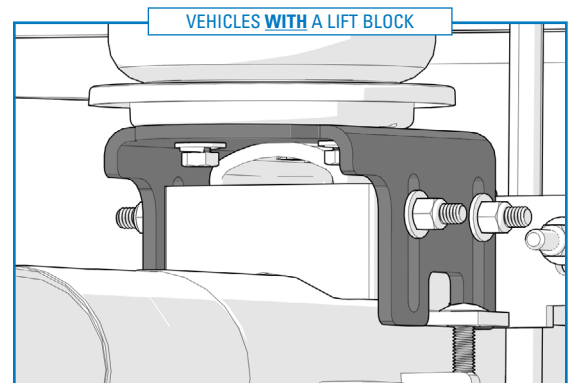

15A

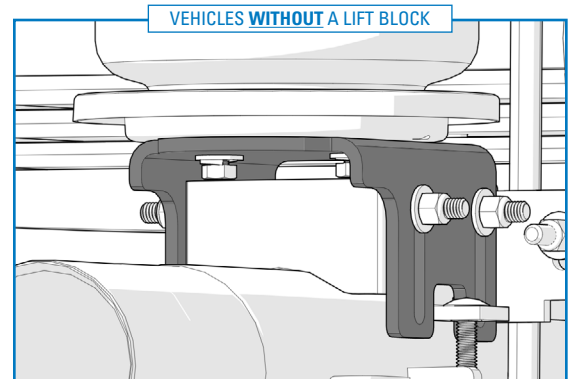

15B

16 INSTALL HEAT SHIELD

On the passenger side of the vehicle, the exhaust pipe bends around the axle near the air spring assembly.

Two heat shields are supplied to provide increased protection from the heat.

Bend tabs on the heat shields so the required $\frac{1}{2}$ " of dead space exists between the heat shield and exhaust when attached.

Attach the heat shields to the exhaust pipe using two ring clamps (as shown in Figure 16).

Each hose clamp holds a tab against exhaust pipe.

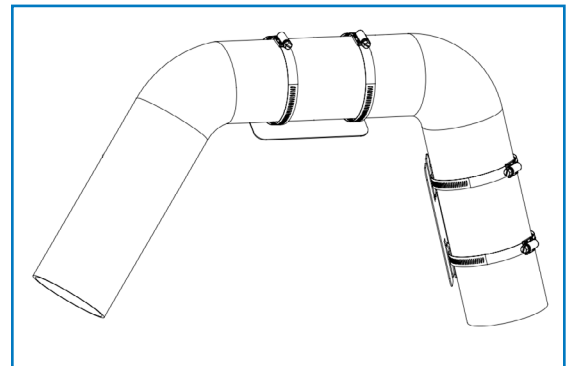

16

17 INSTALL AIR LINE

PLEASE NOTE: This kit contains push-to-connect fittings; using scissors or wire cutters to cut the nylon airline will distort the line and cause the connection to leak. THE AIRLINE MUST BE CUT OFF SQUARELY WITH THE NYLON HOSE CUTTER PROVIDED IN THIS KIT OR A SHARP UTILITY KNIFE

Provided in air spring kit are two fill valves. The most common place to install is in place of license plate fasteners. Alternatively, two 5/16" holes can be drilled in a convenient location.

Cut air line assembly into two equal lengths with hose cutter.

Install one air line, route the nylon air line to an air spring fitting and cut the hose. Moisten the end of the air line prior to inserting it into the fitting and push it in until it stops.

Repeat with the other fill valve.

Secure airlines using the tie-straps, away from moving items and heat sources.

Place a 5/16" nut on the air valve. Leave enough of the inflation valve in front of the nut to extend through the hole, install a flat washer, and 5/16" nut and cap (reference Figure 17 for assembly). There should be enough valve exposed after installation—approximately 1/2"—to easily apply a pressure gauge or an air chuck.

If an in-cab inflation kit is being installed, follow the instructions provided with that kit now.

18 CHECK SYSTEM FOR LEAKS

Inflate both air springs to 90 psi and then use a mixture of dish soap and water on all air line connections to detect any air leaks. Large, expanding bubbles indicate a leak (as shown in Figure 18). Repair as necessary and retest.

Inflate air springs to a predetermined value and on following day recheck pressure.

If one or both of air springs have lost pressure, an air leak is present. Leak must be repaired, and then retested until no leaks exist.

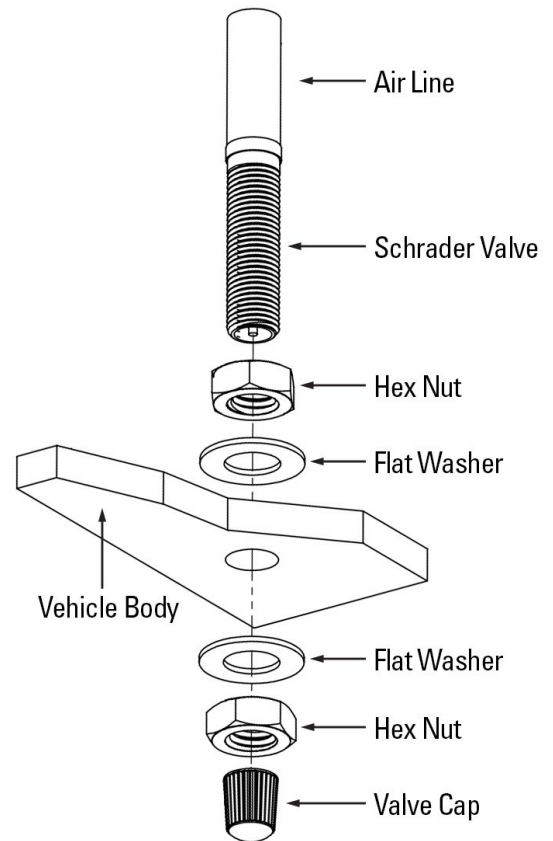

17



18

19 AFTER COMPLETING THE INSTALLATION

PLEASE REMEMBER:

Install wheels and torque fasteners to manufacturer’s specifications.

Re-torque all fasteners after first 500 miles of driving.

For safe and proper operation, never operate the vehicle under minimum of 10 psi or over maximum of 100 psi in air springs. Staying within pressure limit will ensure maximum air spring life. Failure in doing so may result in a void warranty.

⚠ Do not exceed maximum vehicle payload. Failure to do so may result in failure of the air suspension kit and/or damage to your vehicle.

Thank you again, and congratulations on the installation of the air suspension kit.

OPTIONAL ACCESSORIES

Optional dual needle air gauges are available to monitor pressure in each spring from vehicle cab, as well as a full line of air compressors, air tanks, and solenoids built to work with and control your air spring system.

OPERATING YOUR VEHICLE WITH AIR SUSPENSION

Air springs have minimum and maximum pressure requirements. Never operate your vehicle with less than 10 psi in air spring and never inflate air springs over 100 psi. Damage to air springs will result.

Check air pressure in air springs daily for first couple of days to ensure a leak has not developed. Air springs are designed to maintain the vehicles stock ride height with a load. Do not use the air springs as a means to lift vehicle with no load. This will result in a harsh ride.

SERVICING YOUR VEHICLE WITH AIR SUSPENSION

When lifting the vehicle with a floor jack or hoist on the frame, never allow the air spring to limit the travel of the axle. Try to always jack the vehicle on the axle. Suspending the axle with the air spring limiting the axle travel will damage the air spring and void the air spring warranty.

WARRANTY

The owner’s warranty will be void if air springs are run with less than the minimum of 10 psi. See additional warranty for details.