

Installation Manual

REAR BLOCK KIT

VEHICLES WITH FACTORY OVERLOAD SPRINGS

1.0" Rear Block Kit

RAM 2500 (4WD) SRW⁺ with AUX Springs*

RAM 3500 (4WD) SRW⁺ with AUX Springs*

2.0" Rear Block Kit

RAM 2500 (4WD) SRW⁺ with AUX Springs*

RAM 3500 (4WD) SRW⁺ with AUX Springs*

**All kits will not fit Cab & Chassis models, vehicles equipped with high output Cummins package, maximum tow package, or factory air spring package.*

** All kits will not fit 2WD or DRW vehicles.*

VEHICLES WITHOUT FACTORY OVERLOAD SPRINGS

1.0" Rear Block Kit

RAM 2500 (4WD) SRW⁺ without AUX Springs*

RAM 3500 (4WD) SRW⁺ without AUX Springs*

2.0" Rear Block Kit

RAM 2500 (4WD) SRW⁺ without AUX Springs*

RAM 3500 (4WD) SRW⁺ without AUX Springs*

**All kits will not fit Cab & Chassis models, vehicles equipped with high output Cummins package, maximum tow package, or factory air spring package.*

** All kits will not fit 2WD or DRW vehicles.*

Greatly improve your truck's weight distribution and improve vehicle control while towing and hauling heavy loads.





Thank you and congratulations on the purchase of a Rear Block Kit. Please read the entire manual prior to starting the installation to ensure you can complete it once started.

IMPORTANT LEGAL NOTICE

Rear blocks may not be permitted on certain vehicles in your state. Consult your owner's manual, the instructions accompanying this product, and state laws before installing this product.

SAFETY WARNINGS!

Please read and abide the instructions found in this manual, paying close attention to the helpful, cautionary or dangerous warning icons highlighting important safety recommendations and maintenance suggestions throughout this manual.

-  Use caution when disassembling and reassembling the vehicle. The proceeding instructions are guidelines only, the installer is responsible for ensuring that the vehicle is safe for use after performing the installation. It is recommended to use the factory service manual for the model/year of the vehicle when disassembling and assembling factory-related components.
-  Suspension components that use rubber or urethane bushings should be tightened with the vehicle at normal ride height. This will prevent premature wear or failure of the bushing. Prevent the suspension components from overextension by supporting them with a jack.
-  It is not recommended to combine the use of suspension lifts, body lifts, or other lifting methods.
-  **DO NOT** install a Rear Block on top of factory block.
-  Altering the suspension system of your vehicle may cause it to handle differently than it did from the factory. Larger wheel and tire combinations may increase the leverage on the suspension and steering components. This changes the way your vehicle handles and responds to abrupt maneuvers. Operate your vehicle at reduced speeds in all conditions to prevent loss of control. Failure to do so may result in serious injury.

	<p>HELPFUL INSTALL TIP</p> <p><i>Additional information that could potentially make the job a little easier.</i></p>
	<p>PLEASE USE CAUTION</p> <p><i>Unsafe practices could result in damage to you or your vehicle, or others.</i></p>
	<p>DANGER WARNING</p> <p><i>Hazards which could result in severe personal injury or death.</i></p>

BEFORE STARTING THE INSTALLATION

Ensure the application information is correct for the make, model and year of the vehicle you are installing the kit on.

PRE-MEASUREMENTS TO ENSURE FITMENT ON VEHICLE

In order to ensure the kit fits properly, you should measure the length of your vehicle’s existing U-bolts and compare them to the new U-bolts included in this kit. before removing the old U-bolts. using the math shown below:

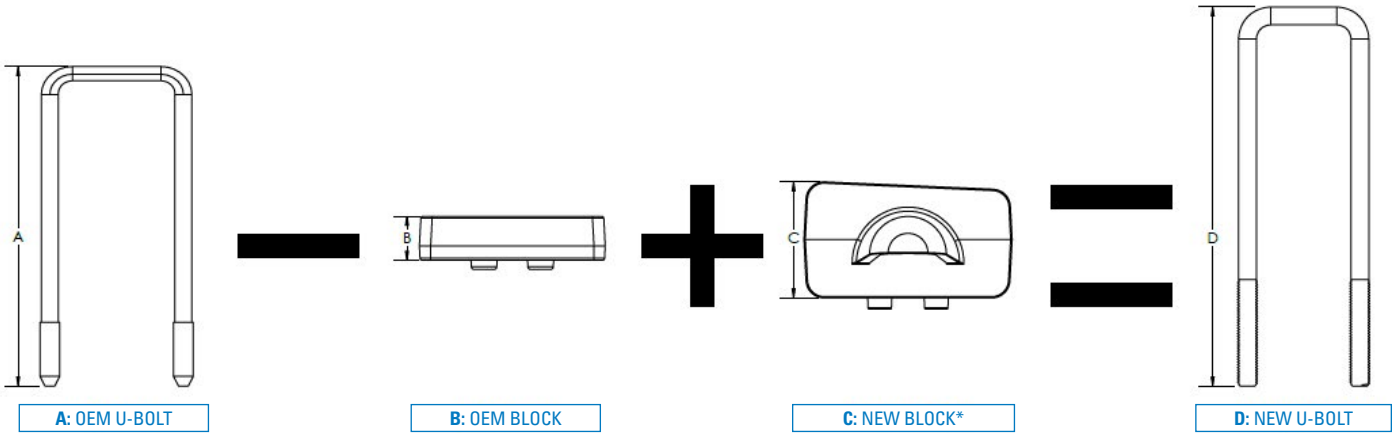

If the sum of measurement **A** and **C**, minus measurement **B**, is equal or less than to the length of the new U-bolts (**A-B+C=D**), then you can proceed with the installation.

⚠ DO NOT install a Rear Block on top of factory block. Trucks equipped with a factory block will have less lift then the stated block height as the factory block is removed during the installation.

PLEASE NOTE:

In some cases, vehicles may not have OEM Blocks, which means that **B** would be zero, and the equation would be simplified to **A+C=D**

+ **Images used above are for reference purpose only and do not always reflect the "new block" included in this kit. Some "new blocks" (C) are non-tapered versions. See **Kit Contents** for specific block details.*



KIT CONTENTS — FOR VEHICLES WITH FACTORY OVERLOAD SPRINGS

Please make sure all the items shown in the kit layout are provided in your kit before starting the installation.

1.0" Rear Block Kit

RAM 2500 (4WD) SRW+ with AUX Springs*
 RAM 3500 (4WD) SRW+ with AUX Springs*

*Will not fit Cab & Chassis models, vehicles equipped with high output Cummins package, maximum tow package, or factory air spring package.

*Will not fit 2WD or DRW vehicles.

1.0" REAR BLOCK – KIT CONTENT		QTY	PART #
A1	1" Rear Block ≈, Non-Tapered	2	HP1853
B3	U-Bolt	4	HP1875-3
C	Nut, M14 x 2 Top Lock Flange	8	HP1872

+ ≈ **PLEASE NOTE:** Trucks equipped with a factory block will have less lift than the stated block height when a factory block is removed during the installation.

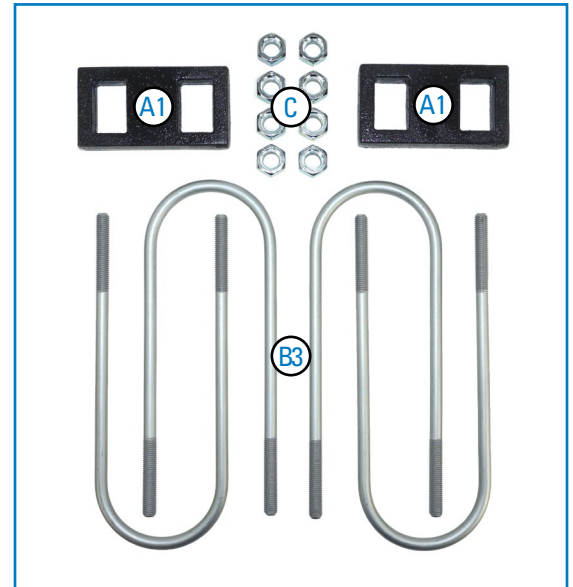

2.0" Rear Block Kit

RAM 2500 (4WD) SRW+ with AUX Springs*
 RAM 3500 (4WD) SRW+ with AUX Springs*

*Will not fit Cab & Chassis models, vehicles equipped with high output Cummins package, maximum tow package, or factory air spring package.

*Will not fit 2WD or DRW vehicles.

2.0" REAR BLOCK – KIT CONTENTS		QTY	PART #
A2^Δ	2" Rear Block ≈, Tapered	2	HP1854
B4	U-Bolt	4	HP1875-4
C	Nut, M14 x 2 Top Lock Flange	8	HP1872

+ ≈ **PLEASE NOTE:** Trucks equipped with a factory block will have less lift than the stated block height when a factory block is removed during the installation.

! ^Δ Install rear block with **SHORT** side towards the **FRONT** of the vehicle. See highlighted note on kit explosion page.

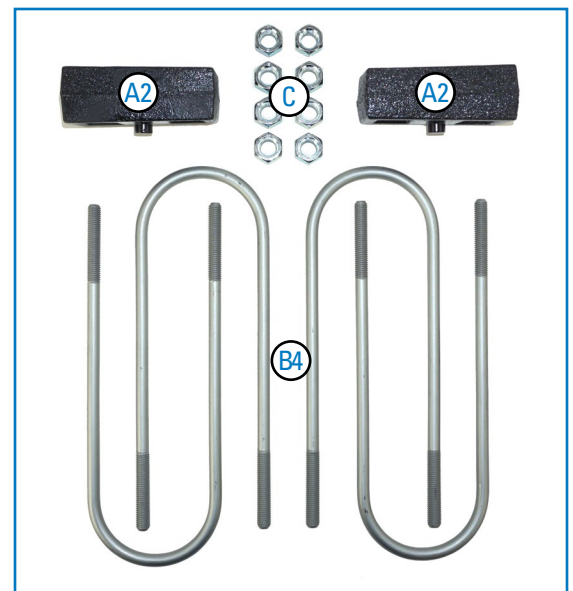

REQUIRED TOOLS

- Hoist or Floor Jack
- Safety Glasses
- 50-280 N•m Range Torque Wrenches
- Safety Stands
- Metric sockets & combination wrenches
- Ratchet

Please make sure all the items shown in this explosion diagram are provided in your kit before starting the installation.

DRIVER SIDE ASSEMBLY SHOWN FOR 1.0" REAR KIT — VEHICLES WITH FACTORY OVERLOAD SPRINGS[⚡]

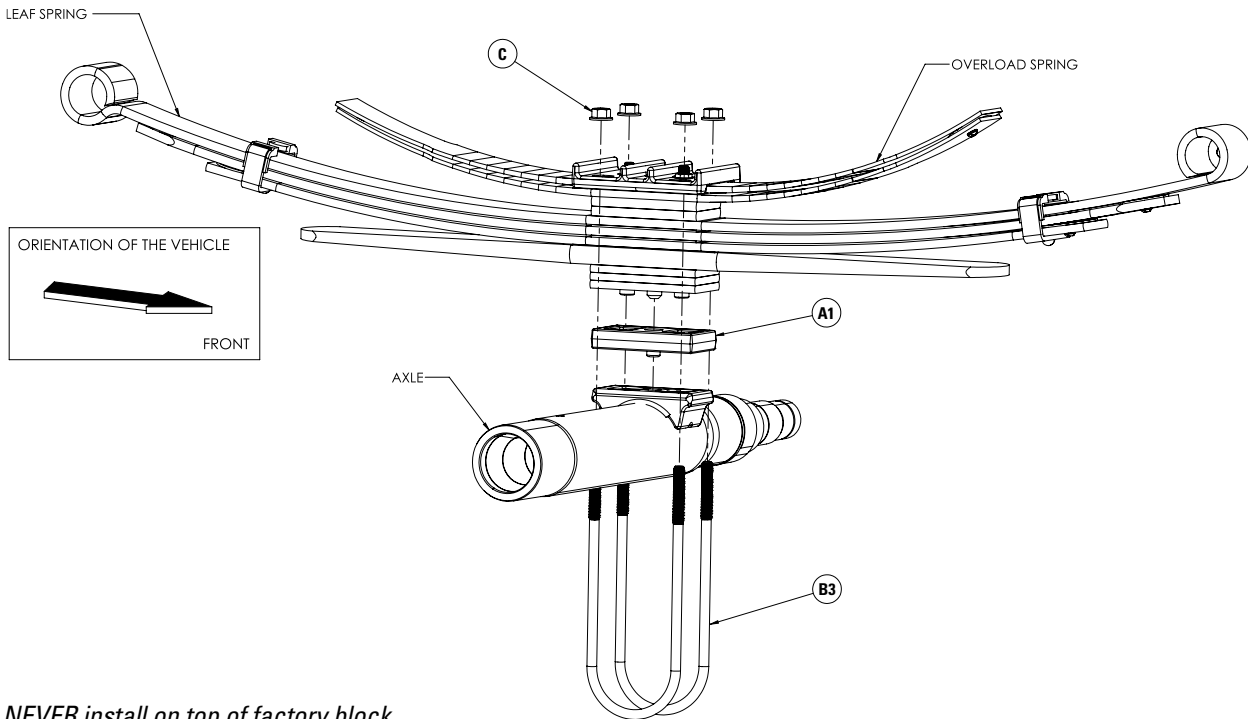

⚠ **NEVER** install on top of factory block.

DRIVER SIDE ASSEMBLY SHOWN FOR 2.0" REAR KIT — VEHICLES WITH FACTORY OVERLOAD SPRINGS[⚡]

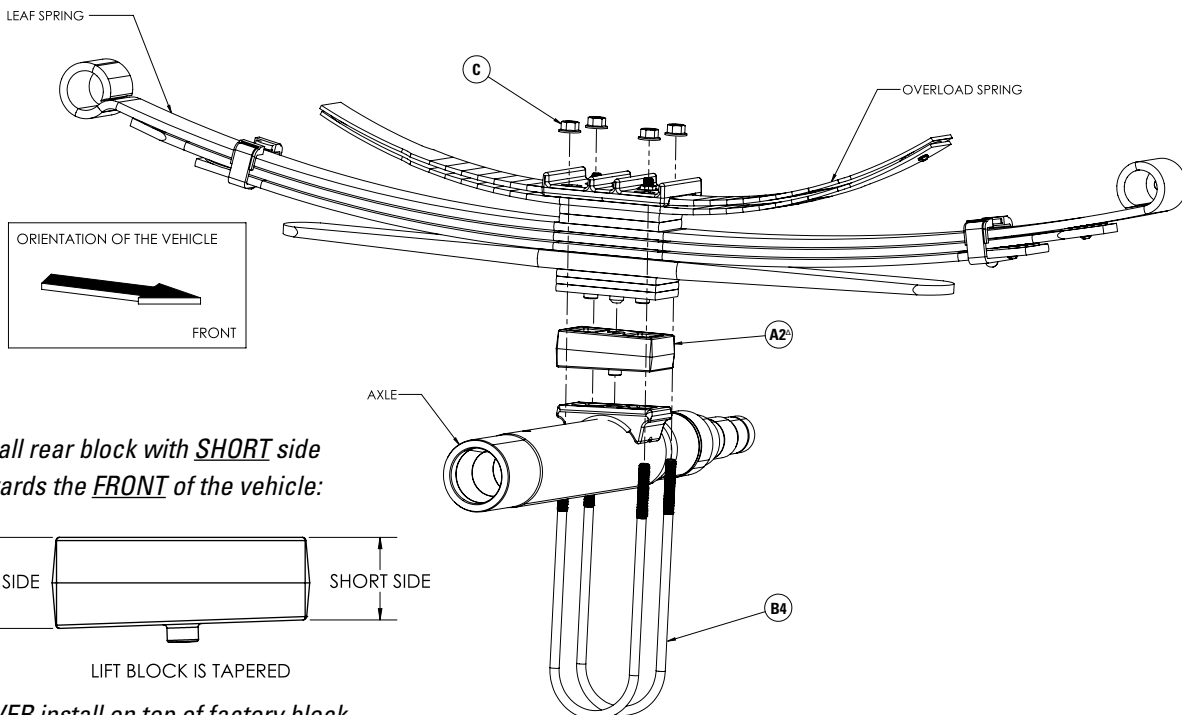

⚠ ^Δ Install rear block with **SHORT** side towards the **FRONT** of the vehicle:

⚠ **NEVER** install on top of factory block.

[⚡] See kit fitment application notes on Page 4

KIT CONTENTS — FOR VEHICLES WITHOUT FACTORY OVERLOAD SPRINGS

Please make sure all the items shown in the kit layout are provided in your kit before starting the installation.

1.0" Rear Block Kit

RAM 2500 (4WD) SRW+ without AUX Springs*

RAM 3500 (4WD) SRW+ without AUX Springs*

*Will not fit Cab & Chassis models, vehicles equipped with high output Cummins package, maximum tow package, or factory air spring package.

*Will not fit 2WD or DRW vehicles.

1.0" REAR BLOCK – KIT CONTENT		QTY	PART #
A1	1" Rear Block ≈, Non-Tapered	2	HP1853
B1	U-Bolt	4	HP1875-1
C	Nut, M14 x 2 Top Lock Flange	8	HP1872

+ ≈ **PLEASE NOTE:** Trucks equipped with a factory block will have less lift than the stated block height when a factory block is removed during the installation.

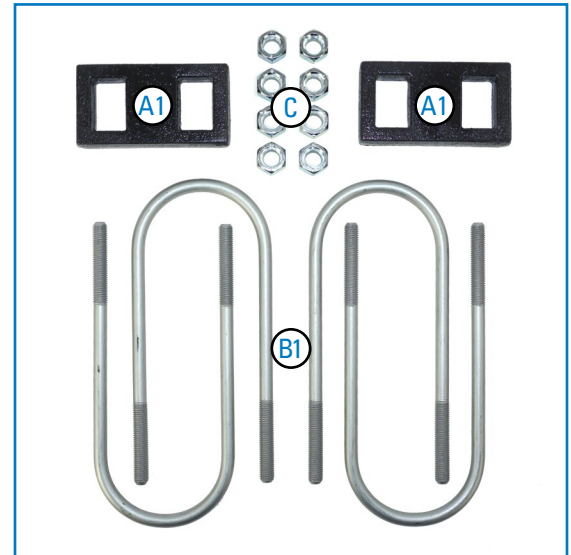

2.0" Rear Block Kit

RAM 2500 (4WD) SRW+ without AUX Springs*

RAM 3500 (4WD) SRW+ without AUX Springs*

*Will not fit Cab & Chassis models, vehicles equipped with high output Cummins package, maximum tow package, or factory air spring package.

*Will not fit 2WD or DRW vehicles.

2.0" REAR BLOCK – KIT CONTENT		QTY	PART #
A2^Δ	2" Rear Block ≈, Tapered	2	HP1854
B2	U-Bolt	4	HP1875-2
C	Nut, M14 x 2 Top Lock Flange	8	HP1872

+ ≈ **PLEASE NOTE:** Trucks equipped with a factory block will have less lift than the stated block height when a factory block is removed during the installation.

! ^Δ Install rear block with **SHORT** side towards the **FRONT** of the vehicle. See highlighted note on kit explosion page.

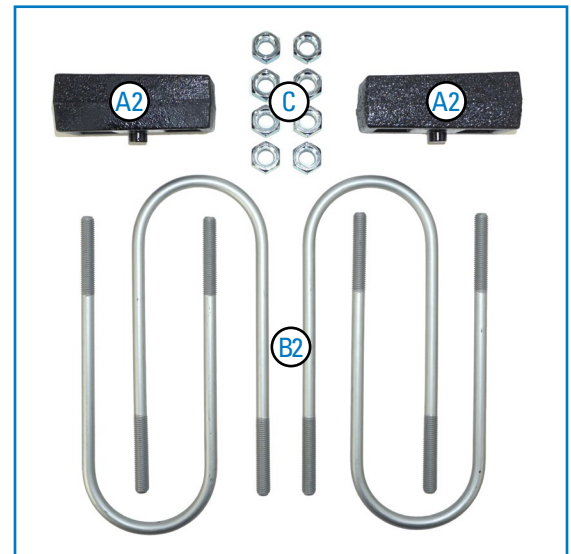

REQUIRED TOOLS

- Hoist or Floor Jack
- Safety Glasses
- 50-280 N•m Range Torque Wrenches
- Safety Stands
- Metric sockets & combination wrenches
- Ratchet

Please make sure all the items shown in this explosion diagram are provided in your kit before starting the installation.

DRIVER SIDE ASSEMBLY SHOWN FOR 2.0" REAR KIT — VEHICLES WITHOUT FACTORY OVERLOAD SPRINGS:

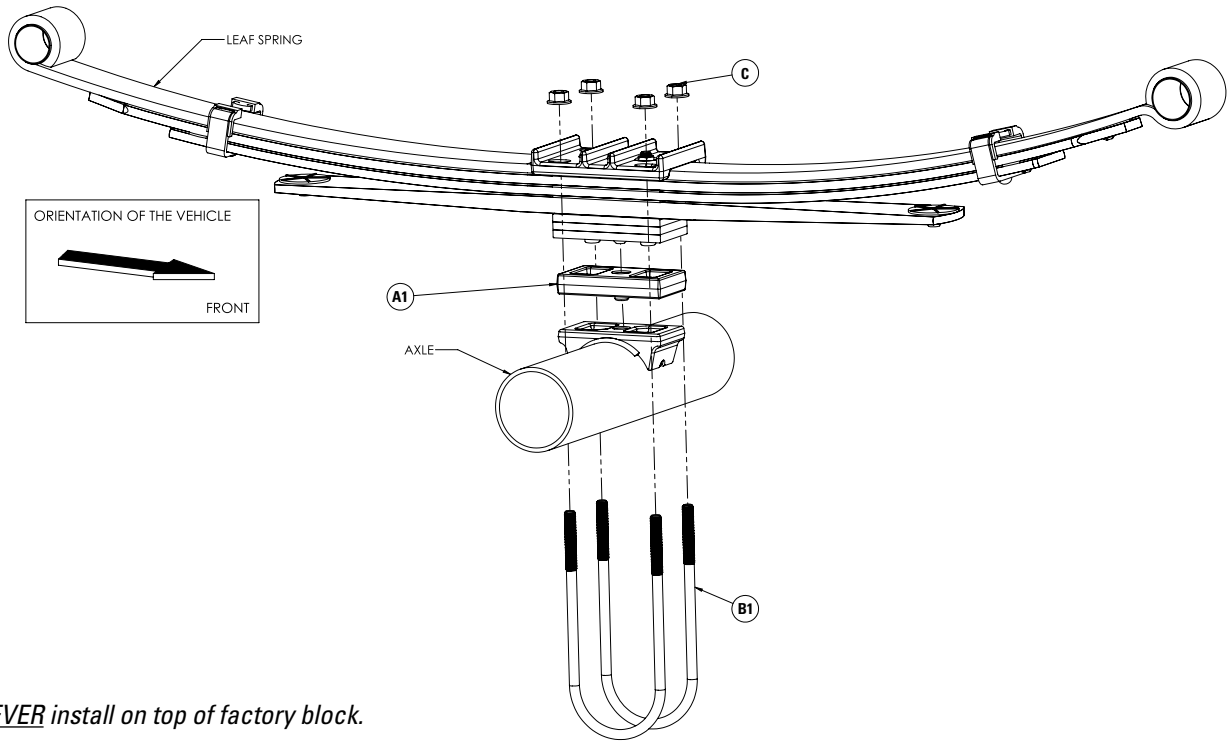

⚠ **NEVER** install on top of factory block.

DRIVER SIDE ASSEMBLY SHOWN FOR 2.0" REAR KIT — VEHICLES WITHOUT FACTORY OVERLOAD SPRINGS:

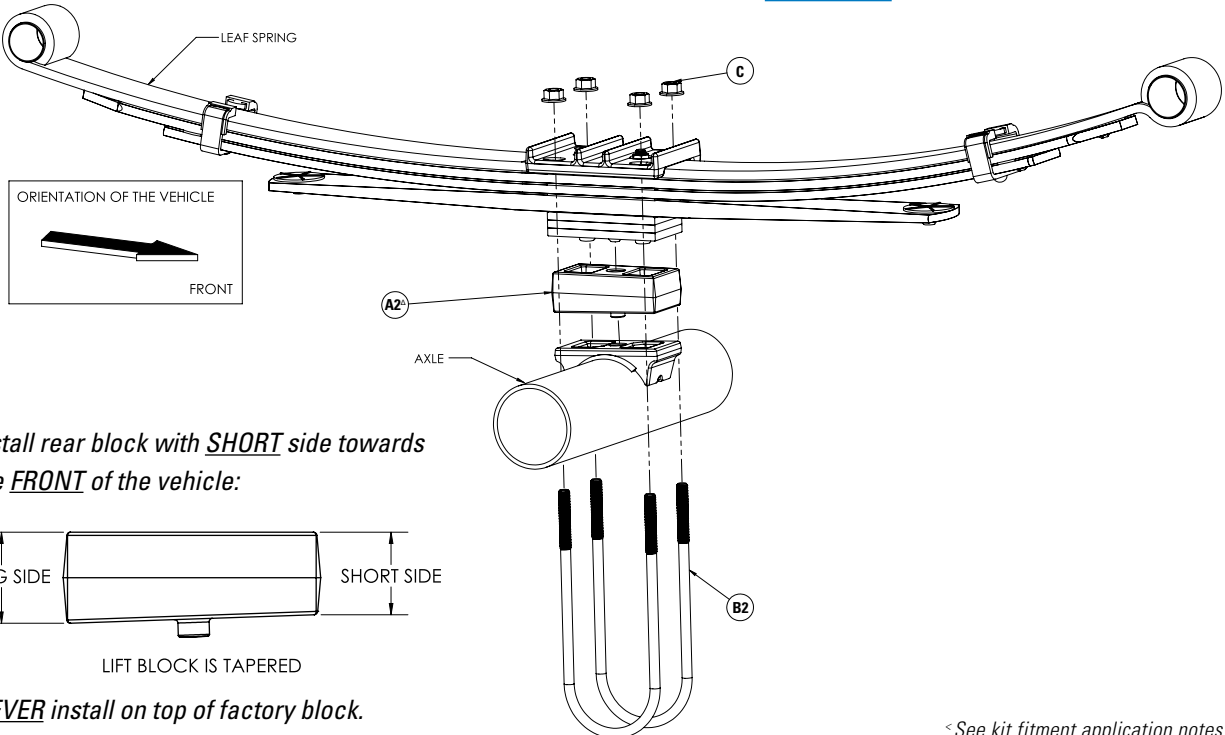

⚠ ^Δ Install rear block with **SHORT** side towards the **FRONT** of the vehicle:

⚠ **NEVER** install on top of factory block.

⚠ See kit fitment application notes on Page 6

INSTALLATION INSTRUCTIONS

1 MEASURE STOCK RIDE HEIGHT

After ensuring the kit will fit properly using the measurement system on the previous page, park the vehicle on a level surface.

Using a measuring tape, measure the distance between the center of the wheel hub and the bottom of the fender well (shown in Figure 1). This will give you your ride height.

Note the ride height for all four corners.

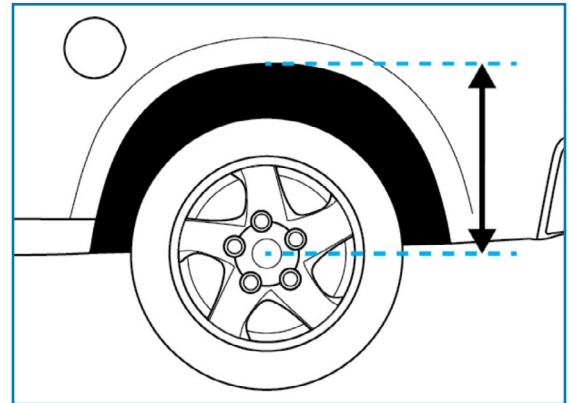

1

2 RAISE VEHICLE

Place wheel chocks in front of and behind both front wheels.

Raise the rear of the truck high enough to allow full extension of the suspension.

Place two jack stands under the frame and support the axle with a jack.

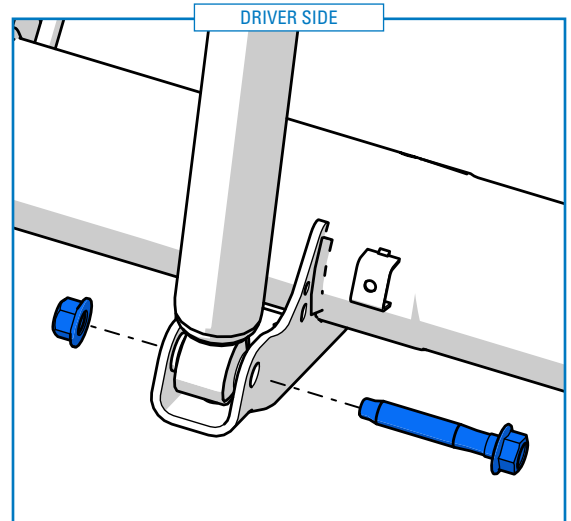

3

COMPLETE THE BELOW INSTALLATION PROCESS ON ONE SIDE OF THE VEHICLE AT A TIME

3 REMOVE THE LOWER SHOCK BOLT

Remove the nut and bolt securing the shock absorber to the axle (as shown in Figure 3).

Retain the nut and bolt for reuse later in the installation (Step 8).

4 REMOVE OEM U-BOLTS

Remove the 4 OEM leaf spring U-bolt nuts (as shown in Figure 4).

Remove the OEM U-bolts while leaving the U-bolt plate in place.

Discard the factory U-bolts and nuts as they will not be reused.

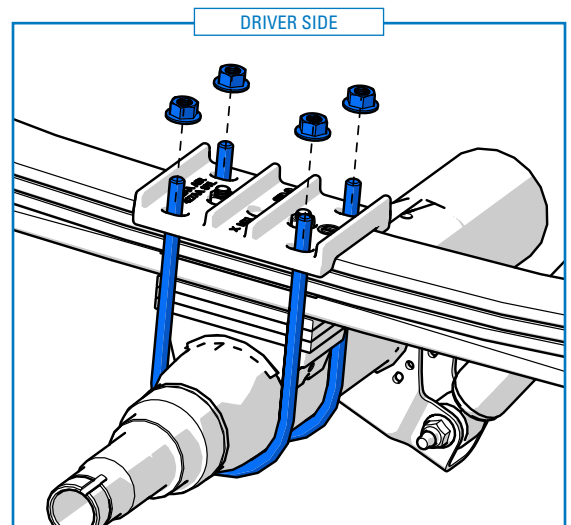

4

5 LOWER AXLE

Lower the axle enough to allow space for the rear block to be placed between the leaf springs and the spring perch on the axle.

PLEASE NOTE: some models may have a factory block installed in the vehicle. Remove this block if equipped.

⚠ WARNING: DO NOT install a rear block on top of OEM or other aftermarket lift blocks. Damage to the vehicle will occur.

6 INSTALL REAR BLOCK

Place the rear block on the leaf spring perch ensuring the alignment pin on block is seated in the hole on leaf spring perch.

⚠ IMPORTANT INSTALLATION NOTE FOR 2" BLOCKS ONLY:
Install the 2" rear block with the SHORT side facing towards the FRONT of the vehicle.

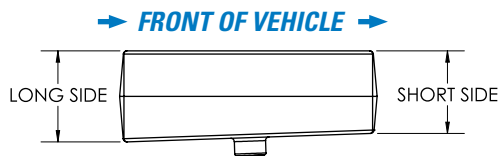

Raise the axle until the block is flat against the bottom of the leaf spring. Ensure the alignment pin in the leaf spring are seated in the holes on the block*.

***PLEASE NOTE:** The block pin must not touch the axle. If the alignment pin is too long in length or the alignment hole is not deep enough, it is recommended to grind off some of the pin so the block sits flush against the bottom of the leaf spring. There should be no gap between the blocks and the leaf spring.

7 INSTALL U-BOLTS

Place the provided U-bolts under the axle and through the leaf spring retainer plate.

Position the U-bolts (as shown in Figure 7) and secure using the provided M14 flange nuts.

Tighten the nuts evenly until they are snug, but **DO NOT** fully torque at this stage.

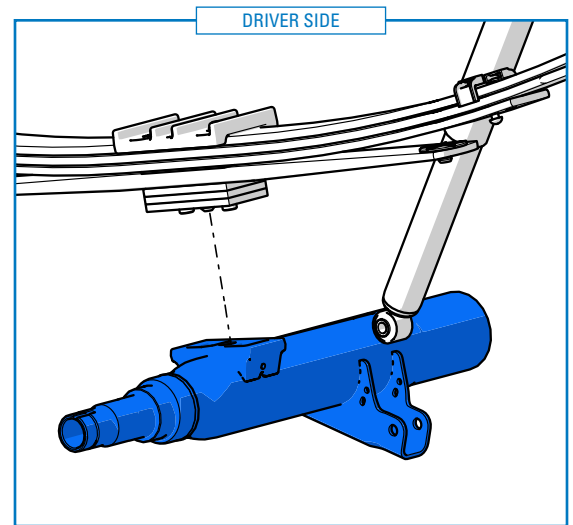

5

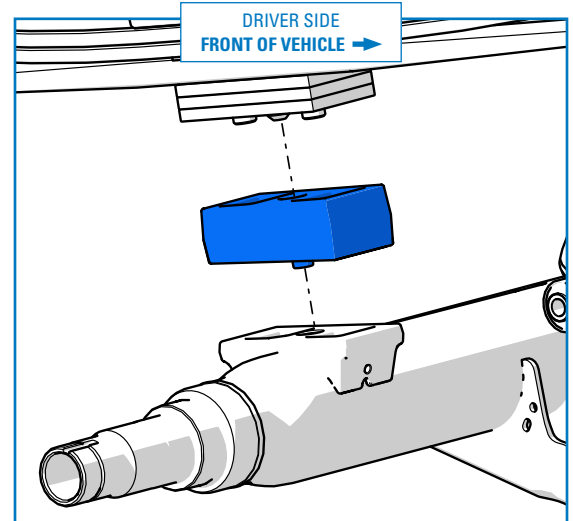

6

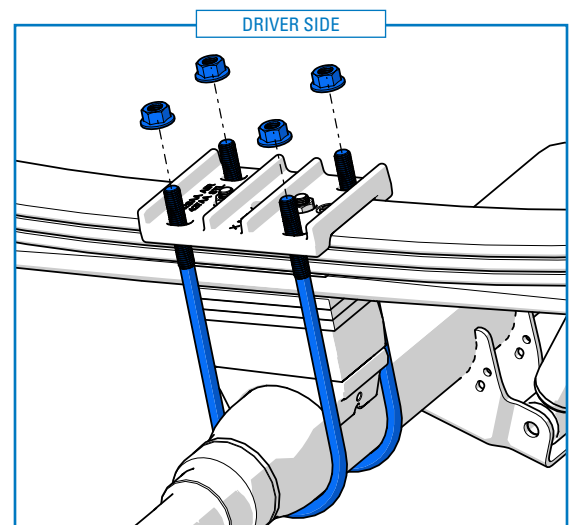

7

8 RE-ATTACH THE LOWER SHOCK MOUNT

Re-install the lower shock mount using the previously removed hardware (from Step 3).

Do not torque hardware at this stage.

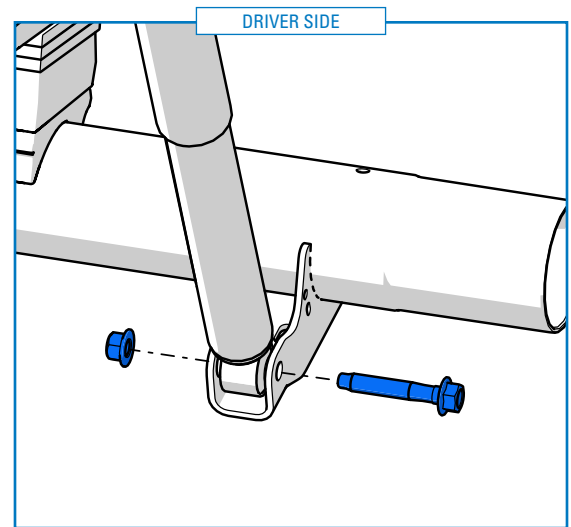

9 TORQUE HARDWARE

Lower the truck, so it is resting on its tires at normal ride height.

LOWER SHOCK MOUNT BOLT

Torque the lower shock mount bolt to the torque values listed below depending on your model year:

RAM 2500

- ▶ 2003-2013 136 N•m [100 ft-lbs]
- ▶ 2014-2021 185 N•m [136 ft-lbs]
- ▶ 2022-2025 180 N•m [133 ft-lbs]

RAM 3500

- ▶ 2003-2021 136 N•m [100 ft-lbs]
- ▶ 2022-2025 190 N•m [140 ft-lbs]

U-BOLTS

For 2003-2021 Model Year Vehicles: Tighten the four M14 U-bolt nuts equally in a cross pattern (shown in Figure 9) and torque to the values listed below per your model year:

- ▶ 2003-2013 149 N•m [110 ft-lbs]
- ▶ 2014-2018 136 N•m [100 ft-lbs]
- ▶ 2019-2021 150 N•m [111 ft-lbs]

For 2022-2025 Model Year Vehicles: Torque the four M14 U-bolt nuts in a cross pattern (shown in Figure 9) in four stages:

- Step 1:** Torque all nuts to 75 N•m [55 ft-lbs]
- Step 2:** Then torque all nuts to 125 N•m [92 ft-lbs]
- Step 4:** Finally, tighten each nut to 175 N•m [129 ft-lbs]

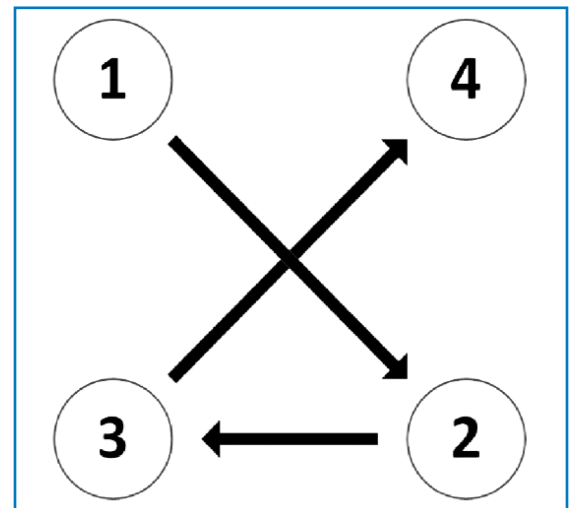

Congratulations!

You have completed the installation

POST INSTALLATION REQUIREMENTS

⚠ Vehicle damage may result if the post installation checks are not performed.

SETTLE SUSPENSION

After the kit installation is complete and the vehicle is on the ground at its normal ride height, roll the vehicle backward and forward to settle the suspension.

TIGHTEN COMPONENTS

Tighten all components containing rubber bushings to the specified torque values.

FINAL CHECK & TEST

Verify adequate tire, wheel, brake line and ABS wire clearance by turning the front wheels completely to the left and then to the right. Ensure brake/ABS lines are not stretched when the suspension is at full droop. Test and inspect steering, brake and suspension components.

WHEEL ALIGNMENT & HEADLIGHT ADJUSTMENT

After the kit installation is complete, a professional wheel alignment must be performed by a certified alignment technician to re-align the vehicle to within factory specifications. Additionally, ensure that the vehicles headlights are aimed properly. If not, a headlight alignment is required as well. If not properly aligned it can cause increased tire and suspension component wear.

RIDE HEIGHT SENSOR CALIBRATION

Factory ride height calibration routine must be performed for rear shock absorber suspension height sensor if vehicle is equipped with dynamic rear suspension.

VEHICLE RE-TORQUE & SAFETY INSPECTION

After the kit installation and adjustments have been completed and within 50 miles of driving, perform a check over of all applicable fasteners and hardware to ensure they are adequately tightened to the specifications given (or as noted in the vehicle's factory service manual).

WARRANTY

To be eligible for warranty, the owner must submit their warranty card or register online within 30 days of the purchase date.

