

Installation Manual

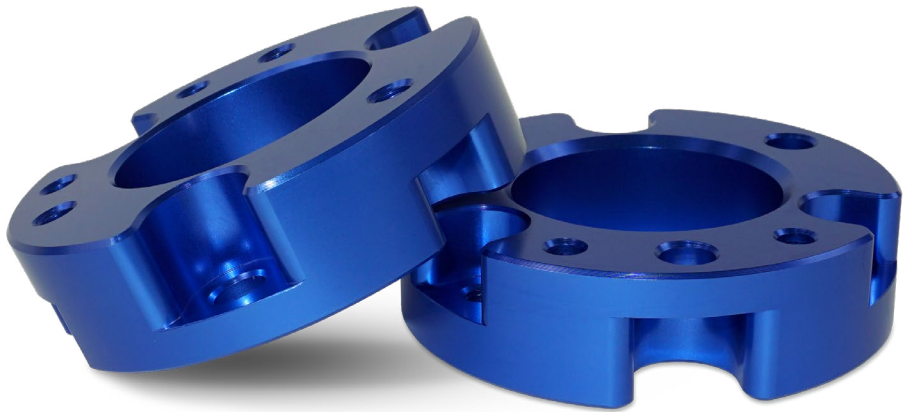

10659 LIFT KIT

2.0" Lift Kit Ford Bronco (4WD)*

**Will not fit Bronco Sports models, Badlands / Sasquatch package equipped models / Wildtrack (or first edition models), or models equipped with Bilstein Shocks*

Improve your truck's off-road capability by increasing ground and wheel well clearance to accommodate larger tires for better traction and a more aggressive stance.

Thank you and congratulations on the purchase of a Lift Kit. Please read the entire manual prior to starting the installation to ensure you can complete it once started.

KIT LAYOUT

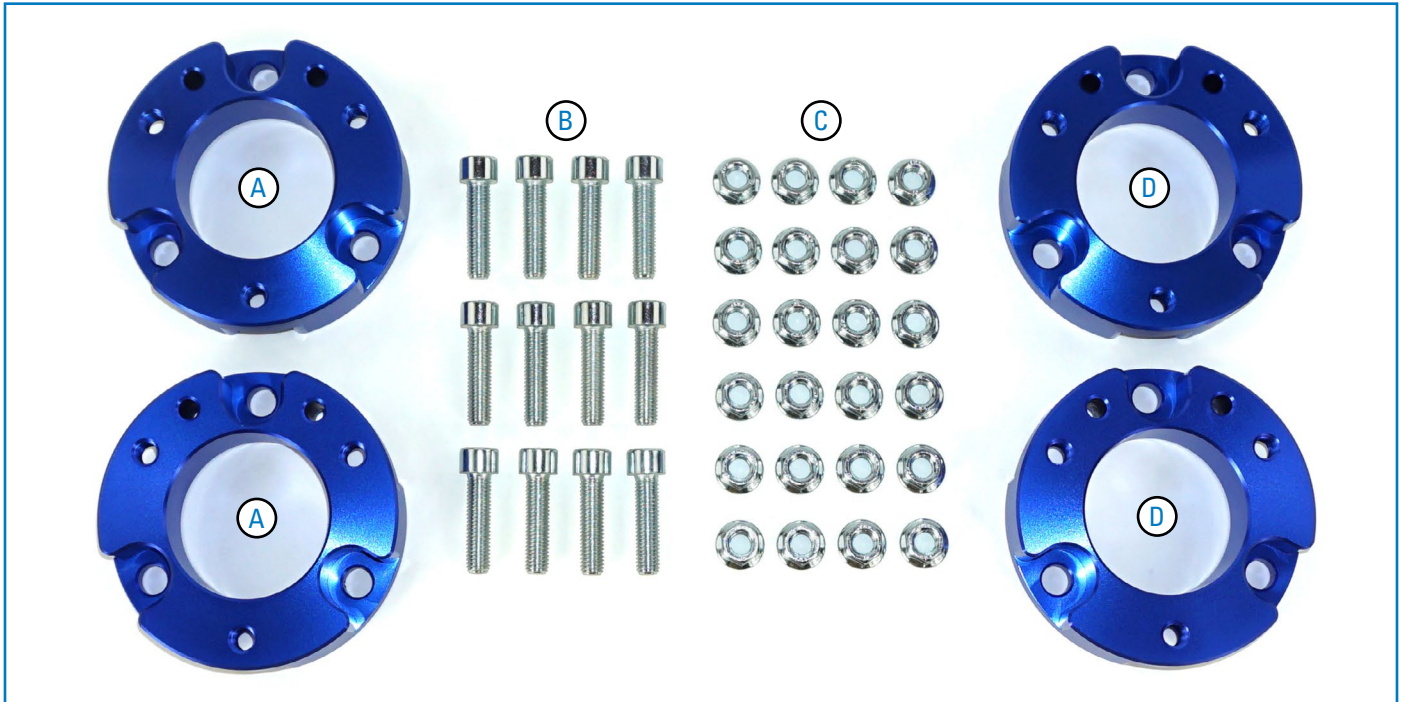

KIT CONTENTS

Please make sure all the items shown in the kit layout above are provided in your kit before starting the installation.

KIT CONTENTS		QTY	PART #
A	Spacer, 2" Front - <i>see part clarification below</i>	2	HP1827
B	Bolt, M10 - 1.5 x 40 mm Socket Head	12	HP1462
C	Nut, M10 - 1.5 Flange	24	HP1457
D	Spacer, 2" Rear - <i>see part clarification below</i>	2	HP2063

REQUIRED TOOLS

- Hoist or Floor Jack
- Safety Stands
- Safety Glasses
- Torque Wrench
- Standard Combination Wrenches
- 7/32" Hex Allen Wrench
- 1-1/8" Wrench or Deep Socket
- Metric & Standard
- Sockets Ratchet

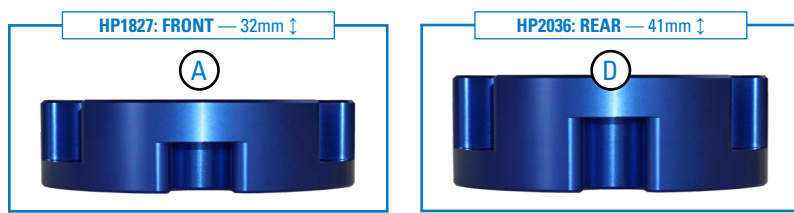

PLEASE NOTE: Due to the suspension geometry and vehicle tolerances, the amount of lift is a base figure. **Spacer thickness does not equate to the amount of lift due to the suspension geometry.** For example: a 1" thick spacer may provide a 2" lift. Always measure the vehicle ride height at all 4 corners before and after installation to ensure the results are as expected.

KIT EXPLOSION DIAGRAM

FRONT LIFT — DRIVER SIDE ASSEMBLY SHOWN
(Passenger side assembly is mirrored)

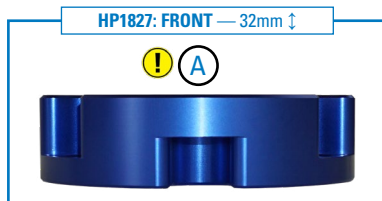
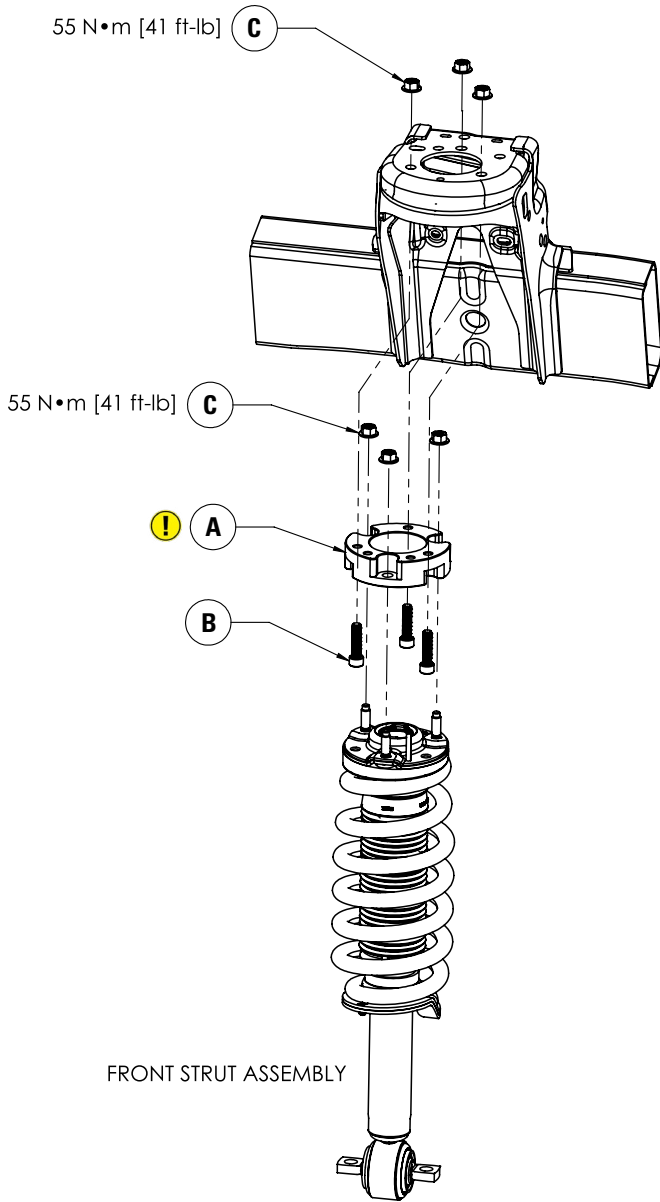

REAR LIFT — DRIVER SIDE ASSEMBLY SHOWN
(Passenger side assembly is mirrored)

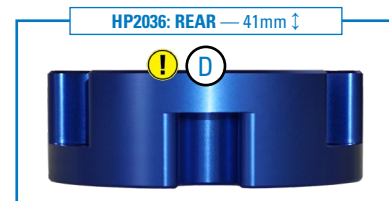
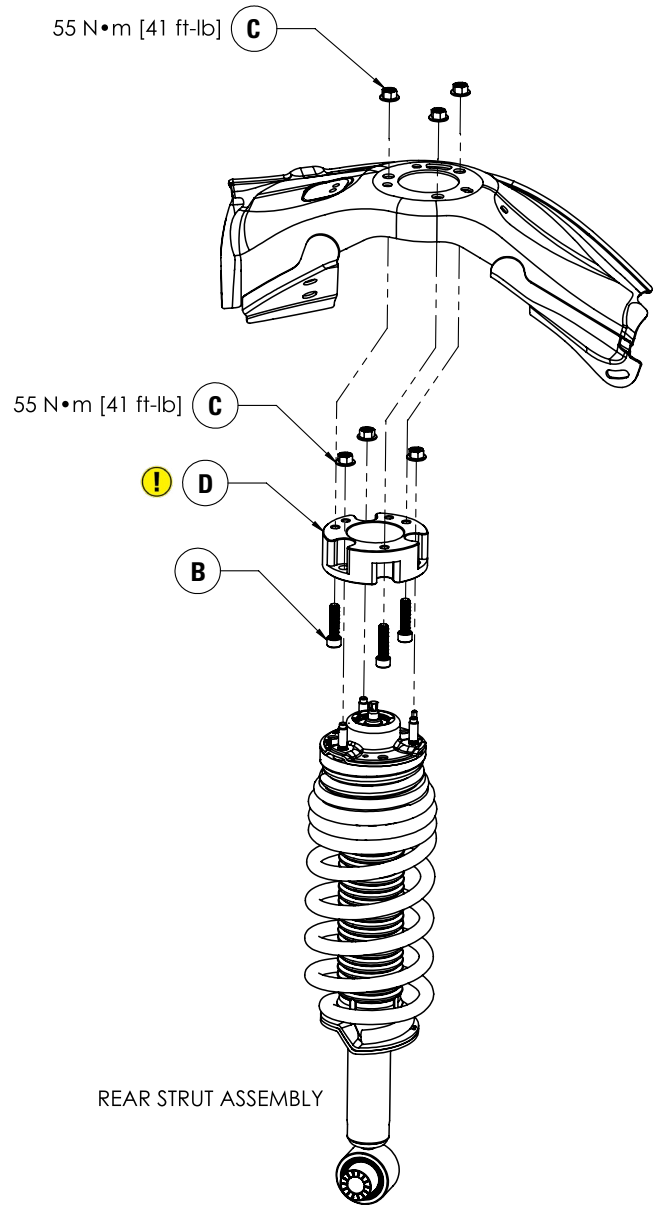

BEFORE STARTING THE INSTALLATION:

Safety Warning!

Altering the suspension system of your vehicle may cause it to handle differently than it did from the factory. Larger wheel and tire combinations may increase the leverage on the suspension and steering components. This changes the way your vehicles handles and responds to abrupt maneuvers. Operate your vehicle at reduced speeds in all conditions to prevent loss of control. Failure to do so may result in serious injury. It is not recommend to combine the use of suspension lifts, body lifts, or other lifting methods.

Installation Warning!

Use caution when disassembling and reassembling the vehicle. The proceeding instructions are guidelines only, the installer is responsible for ensuring that the vehicle is safe for use after performing the installation. It is recommended to use the factory service manual for the model/year of the vehicle when disassembling and assembling factory related components.

Suspension components that use rubber or urethane bushings should be tightened with the vehicle at normal ride height. This will prevent premature wear or failure of the bushing. Prevent the suspension components from overextension by supporting them with a jack.

PLEASE NOTE: Due to the suspension geometry and vehicle tolerances, the amount of lift is a base figure. **Spacer thickness does not equate to the amount of lift due to the suspension geometry.** For example: a 1" thick spacer may provide a 2" lift. Always measure the vehicle ride height at all 4 corners before and after installation to ensure the results are as expected.

WHEEL ALIGNMENT AND HEADLIGHT ADJUSTMENT

It is necessary to have a proper and professional wheel alignment performed by a certified alignment technician to align the vehicle to factory specifications. After the installation is complete, check to ensure that the vehicle's headlights are aimed properly. If not, a headlight alignment is required.



INSTALLATION INSTRUCTIONS: FRONT LIFT**1 MEASURE STOCK RIDE HEIGHT**

Park the vehicle on a level surface.

Using a measuring tape, measure the distance between the center of the wheel hub and the bottom of the fender well (as shown in Figure 1). This will give you your ride height.

Note the ride height for all four corners.

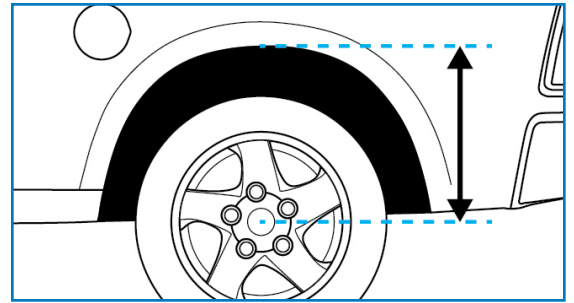

1

2 REMOVE FRONT WHEELS

Place wheel chocks in front of and behind both rear wheels.

Raise the front of the truck high enough to remove both wheels and attain a comfortable working height.

Place two jack stands under the vehicle's frame.

Lower vehicle until the frame is supported by the jack stands.

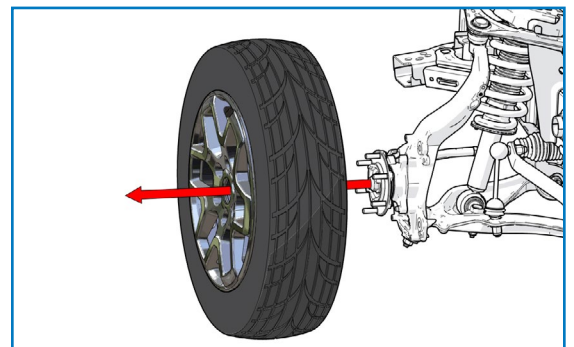

2

3 REMOVE TIE ROD

Remove the nut securing the tie rod to the steering knuckle (as shown in Figure 3).

Use a dead block hammer to strike the steering knuckle and dislodge the tapered mounting pin.

Then remove the tie rod from the knuckle.

Repeat on opposite side of the vehicle.

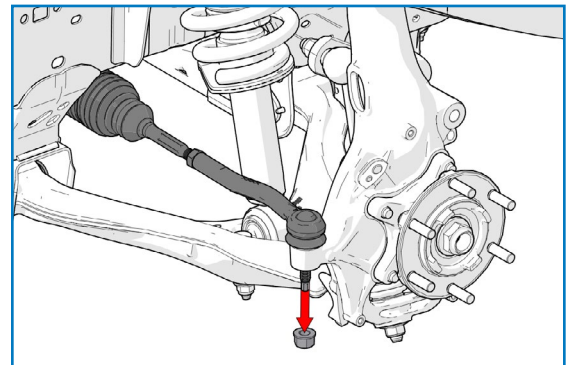

3

4 REMOVE BRAKE LINE BRACKETS

Remove brake line brackets from the steering knuckle (highlighted in Figure 4) to prevent straining the lines during strut removal.

Repeat on opposite side of the vehicle.

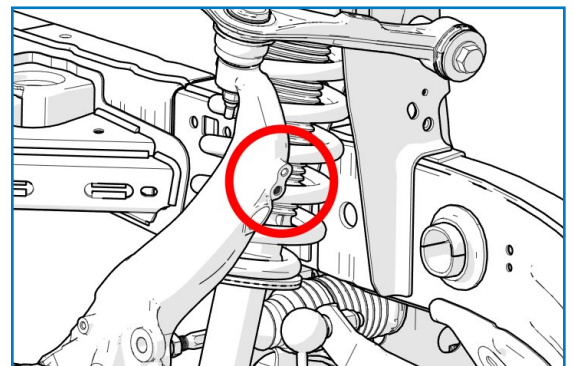

4

5 REMOVE END LINK NUT

Remove the nut securing the sway bar end link to the lower control arm (see Figure 5 for reference).

Pull the end link out of the control arm.

Repeat on opposite side of the vehicle.

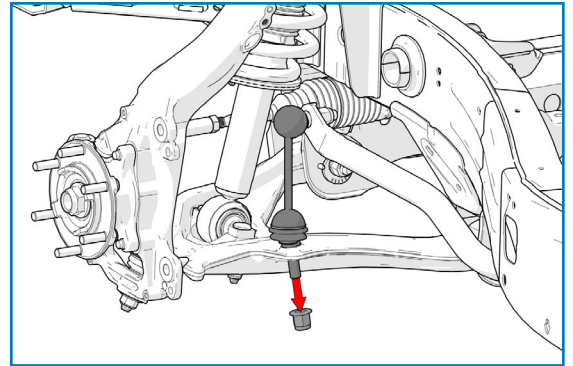

5

6 REMOVE LOWER STRUT NUTS

Remove the two nuts securing the strut assembly to the lower control arm (shown in Figure 6).

Repeat on opposite side of the vehicle.

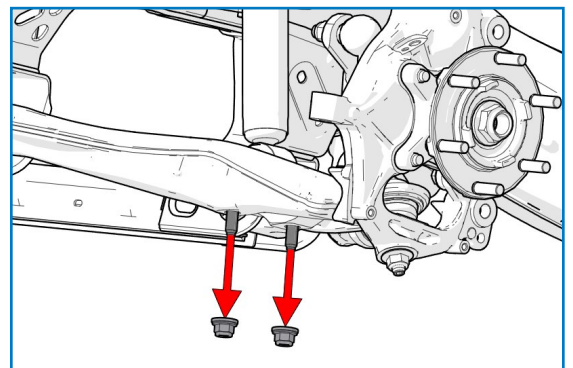

6

7 REMOVE UPPER STRUT NUTS

Remove the three nuts securing the strut assembly to the frame (as shown in Figure 7).

Repeat on opposite side of the vehicle.

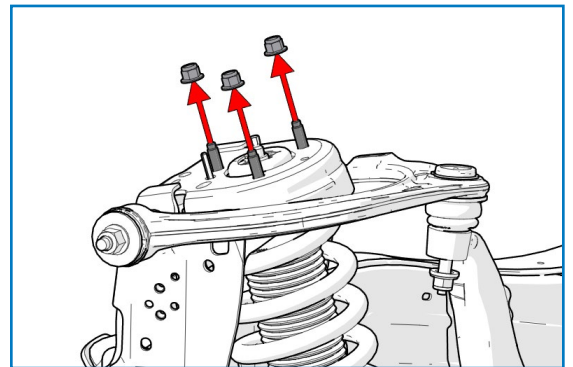

7

8 REMOVE UPPER BALL JOINT NUT

Loosen the nut securing the steering knuckle to the upper control arm, but do not fully remove nut.

Strike the knuckle with a dead blow hammer to dislodge the tapered mounting post securing the upper control arm to the knuckle.

Then remove the nut (as shown in Figure 8) and pull the upper control arm ball joint from the knuckle.

Ensure the steering knuckle does not pull or strain any brake lines when pulled away from the upper control arm.

Repeat on opposite side of the vehicle.

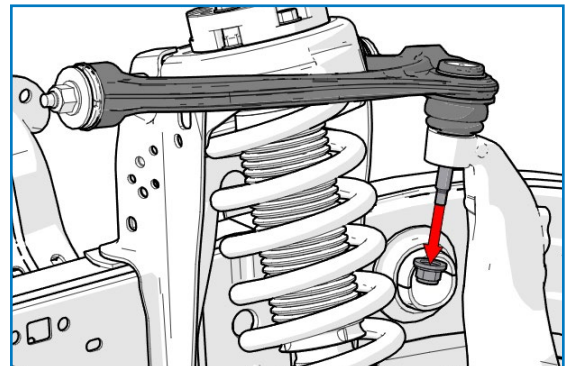

8

9 REMOVE AXLE NUT

Remove the nut securing the axle to the wheel hub (as shown in Figure 9).

Separate the axle from the hub by striking the end with a hammer.

Repeat on opposite side of the vehicle.

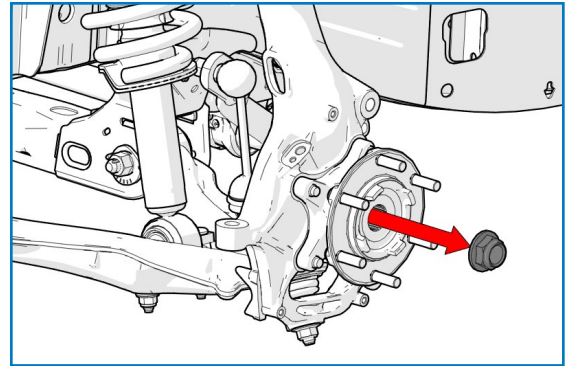

9

10 REMOVE STRUT ASSEMBLY

Push the lower control arm down until the lower strut studs are free from the mounting holes in the lower control arm.

Remove the strut assembly from the vehicle.

Repeat on opposite side of the vehicle.

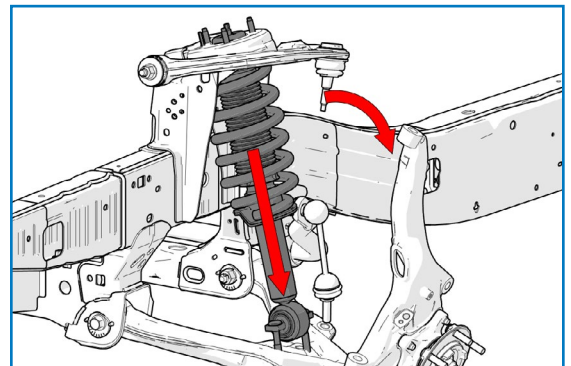

10

11 INSTALL BOLTS IN FRONT SPACER

Install three M10 x 1.5 x 40 mm socket head bolts in each front spacer (as shown in Figure 11).

! *PLEASE NOTE: Front spacers are the shorter of the 2 spacers included in this kit, with a measured height of 32mm.*

Tighten bolts hand tight.

Repeat on opposite side of the vehicle.

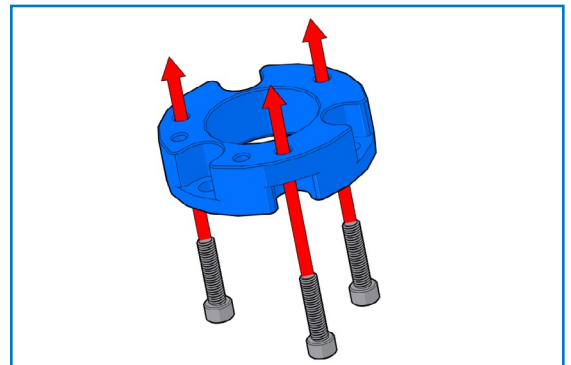

11

12 INSTALL UPPER FRONT SPACER

Place the upper leveling spacer over the upper mounting studs and alignment pin on top of the strut assembly (using Figure 12 as reference).

Secure spacer to strut using three M10 x 1.5 flange nuts

Torque nuts to 55 N•m (41 ft-lbs)

Repeat on opposite side of the vehicle.

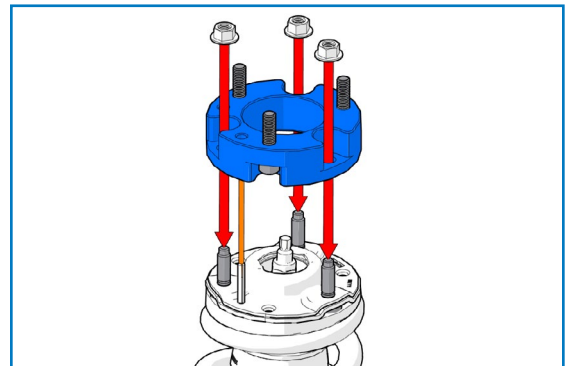

12

13 INSTALL STRUT ASSEMBLY

Install the strut assembly with spacer back into the vehicle (as shown in Figure 13).

Secure the assembly to the frame using three M10 x 1.5 flange nuts.

Torque the flange nuts to 55 N•m (41 ft-lbs).

Repeat on opposite side of the vehicle.

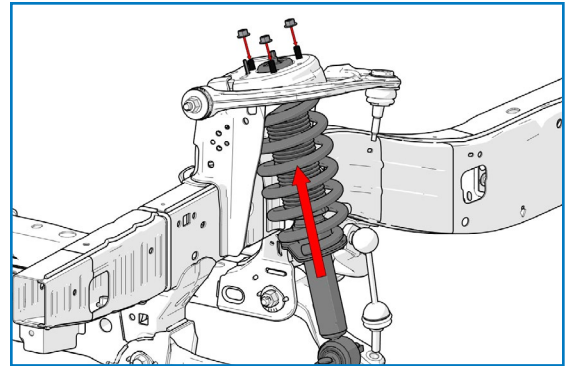

13

14 INSTALL AXLE NUT

Insert the axle shaft through the wheel hub and secure with the axle nut (as shown in Figure 14).

Torque nut to 300 N•m (221 ft-lbs).

Repeat on opposite side of the vehicle.

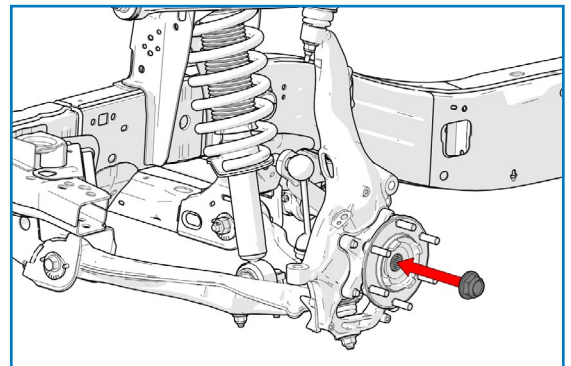

14

15 INSTALL UPPER BALL JOINT NUT

Insert the upper control arm ball stud into the steering knuckle and secure with nut (as shown in Figure 15).

Torque nut to 63 N•m (46 ft-lbs).

Repeat on opposite side of the vehicle.

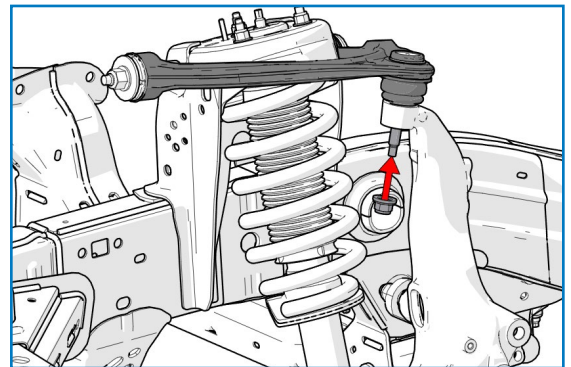

15

16 INSTALL END LINK NUT

Insert the sway bar end link into the lower control arm and secure with the end link nut. (See Figure 16 for reference).

Torque nut to 150 N•m (111 ft-lbs).

! *Suspension components that use rubber or urethane bushings should be tightened with the vehicle at normal ride height. This will prevent premature wear or failure of the bushing.*

Repeat on opposite side of the vehicle.

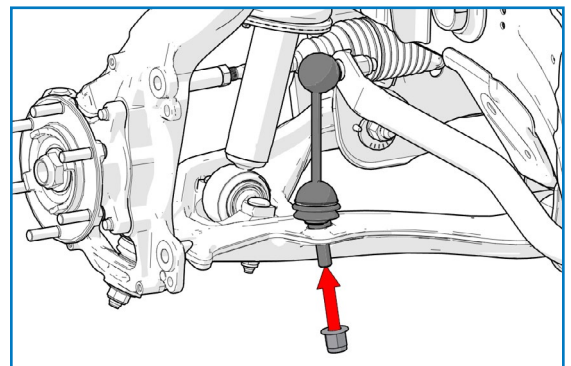

16

17 INSTALL TIE ROD NUT

Insert the tie rod mounting post into the steering knuckle and secure with tie rod nut. (See Figure 17 for reference).

Torque nut to 63 N•m (46 ft-lbs)

Repeat on opposite side of the vehicle.

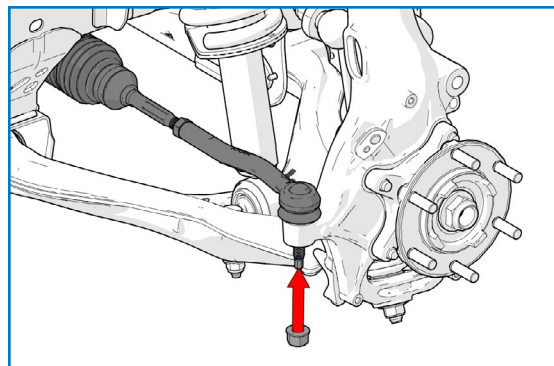

17

18 INSTALL BRAKE LINE BRACKETS

Install the removed brake line brackets (previously removed in Step 4) back into the steering knuckle.

Torque nut to 25 N•m (18 ft-lbs).

Repeat on opposite side of the vehicle.

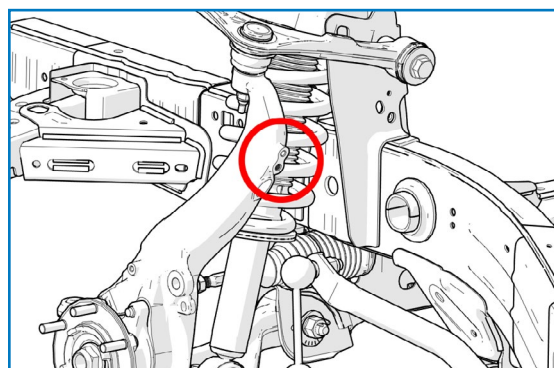

18

19 REINSTALL THE WHEELS

Install the wheels back on both sides of the vehicle and re-install factory lug nuts.

Torque nut to 135 N•m (100 ft-lbs).

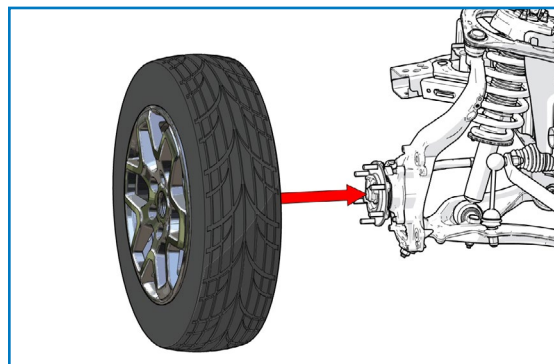

19

Installation for the Rear Lift continues on the following page.

INSTALLATION INSTRUCTIONS: REAR LIFT**20 MEASURE STOCK RIDE HEIGHT**

Park the vehicle on a level surface.

Using a measuring tape, measure the distance between the center of the wheel hub and the bottom of the fender well (as shown in Figure 20). This will give you your ride height.

Note the ride height for all four corners.

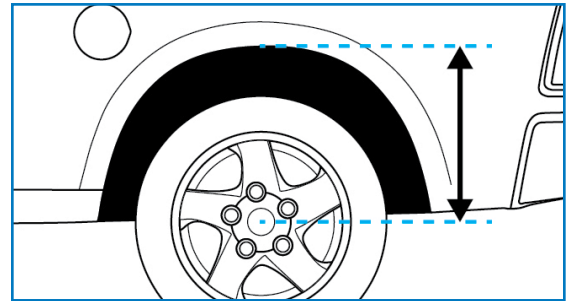

20

21 REMOVE REAR WHEELS

Place wheel chocks in front of and behind both front wheels.

Raise the rear of the truck high enough to remove both wheels and attain a comfortable working height.

Place two jack stands under the vehicle's frame. Lower vehicle until the frame is supported by the jack stands

Remove both rear wheels.

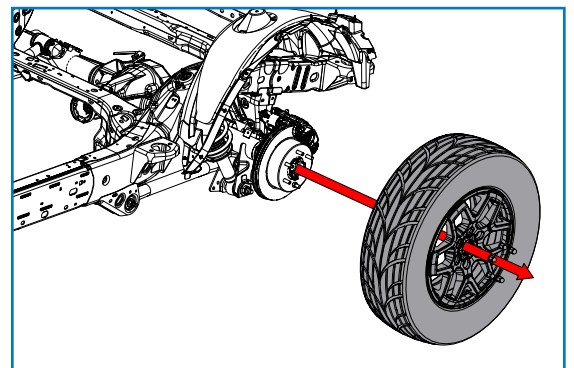

21

22 DETACH TRACK BAR BOTTOM

On the Drivers side, remove the bolt holding the lower end of the track bar (Panhard rod) to the axle (as shown in Figure 22).

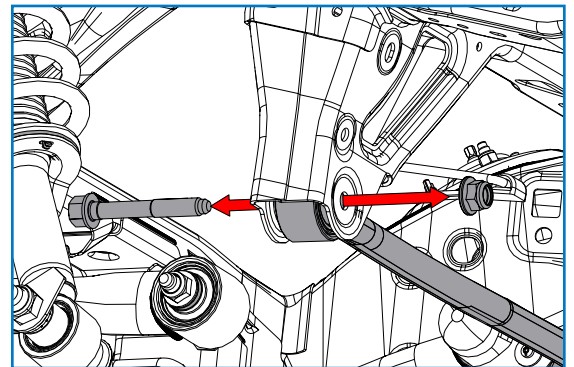

22

23 REMOVE ABS WIRE MOUNT

On the top of the rear differential, unbolt and remove the ABS wire harness holding the wire to the axle (shown in Figure 23).

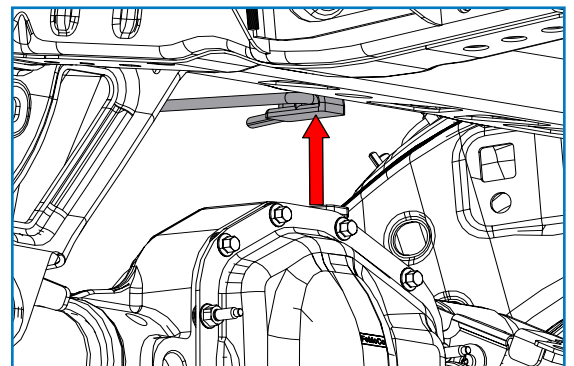

23

24 REMOVE BOTTOM STRUT MOUNT BOLTS

On the bottom of the strut, remove the bolts securing them to the axle (as shown in Figure 24).

Repeat on opposite side of the vehicle.

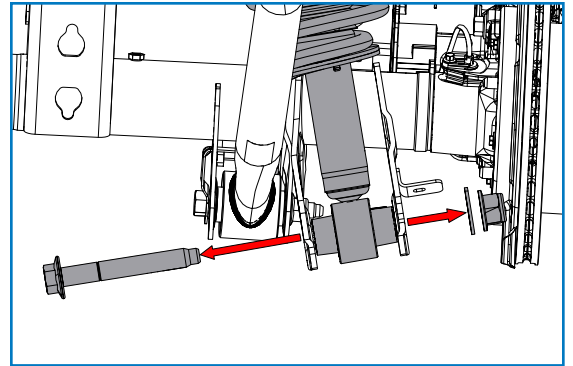

24

25 FENDER LINER REMOVAL

In the wheel well, remove the fender liner to access the top of the strut (as shown in Figure 25).

Repeat on opposite side of the vehicle.

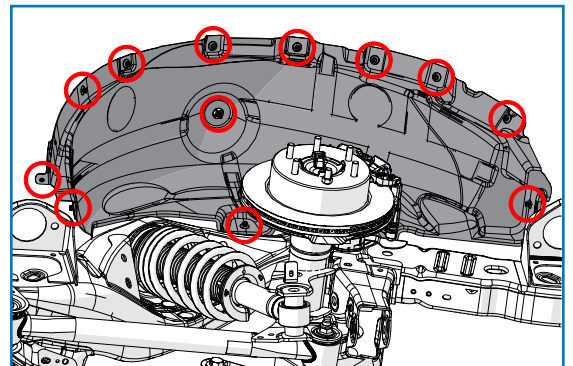

25

26 REMOVE TOP STRUT MOUNT BOLTS

On the top of the strut, remove the three bolts securing the strut to the frame and remove the strut from the vehicle (as shown in Figure 26).

Repeat on opposite side of the vehicle.

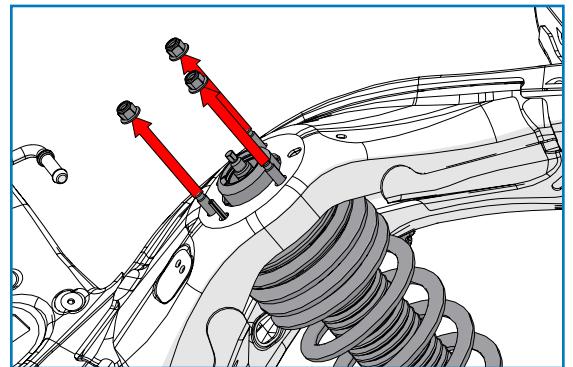

26

27 INSTALL BOLTS IN REAR SPACER

Install three M10 x 1.5 x 40 mm socket head bolts in each rear spacer (as shown in Figure 27).

! *PLEASE NOTE: Rear spacers are the taller of the 2 spacers included in this kit, with a measured height of 41mm.*

Tighten bolts hand tight.

Repeat on opposite side of the vehicle.

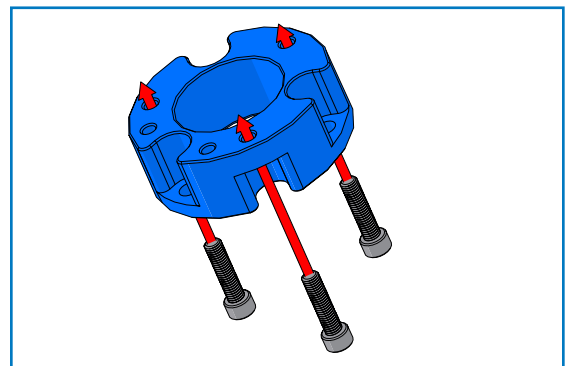

27

28 INSTALL REAR SPACER

Install the spacer on the top of the shock, using three M10 flange nuts (as shown in Figure 28).

Torque to 55 N•m [41 ft-lb]

Repeat on opposite side of the vehicle.

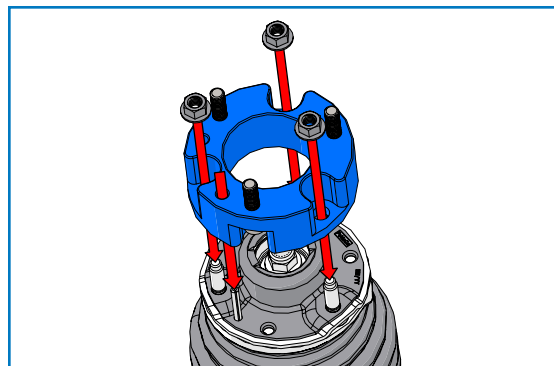

28

29 REINSTALL STRUT ASSEMBLY

Insert the strut with the spacer into the frame, through the original frame holes, making sure the bottom of the strut aligns with the mounting point on the axles (see Figure 29 for reference).

Install three M10 Flange nuts on the top of the strut.

Torque to 55 N•m [41 ft-lb]

Repeat on opposite side of the vehicle.

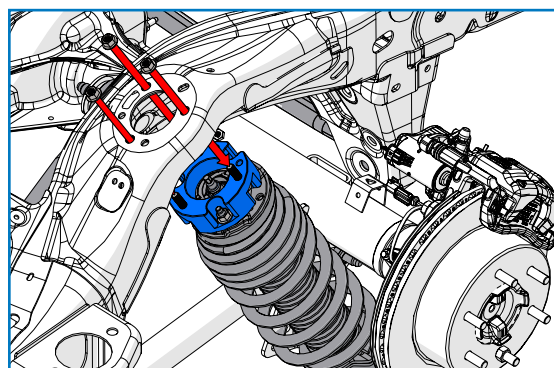

29

30 REINSTALL STRUT LOWER BOLT

Reinstall the lower bolt, washers and nut connecting the strut to the axle (as shown in Figure 30).

Torque to 475 N•m [350 ft-lb]

Repeat on opposite side of the vehicle.

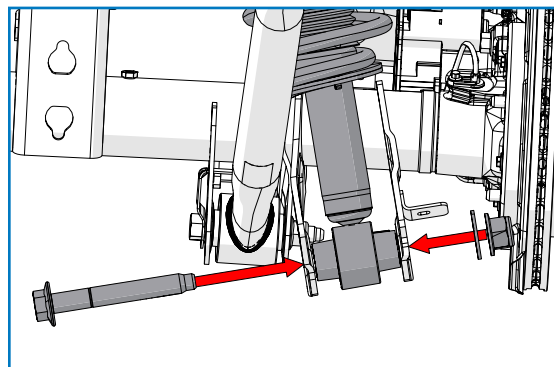

30

31 REINSTALL TRACK BAR BOLT

Reinstall track bar (Panhard rod) on axle (as shown in Figure 31).

Torque to 215 N•m [159ft-lb]

Repeat on opposite side of the vehicle.

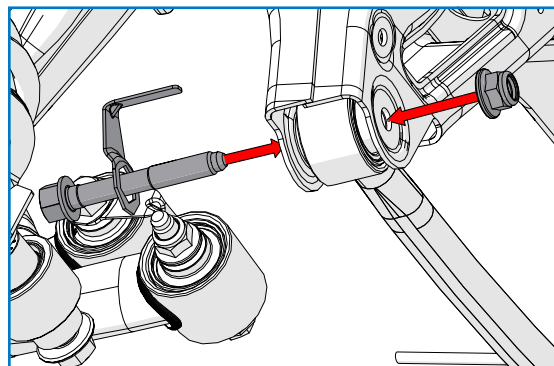

31

32 REINSTALL ABS WIRE MOUNT

Reinstall the ABS wire harness on the top of the rear differential (as shown in Figure 32).

Torque to 25 N•m [18ft-lb]

Repeat on opposite side of the vehicle.

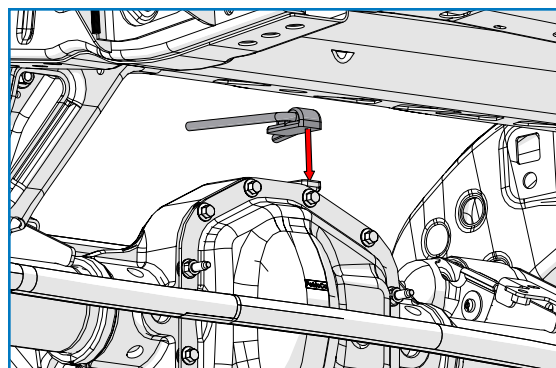

32

33 REINSTALL FENDER LINER

Reinstall the fender liner in the wheel well (as shown in Figure 33).

Torque to 2 N•m [18 in-lb]

Repeat on opposite side of the vehicle.

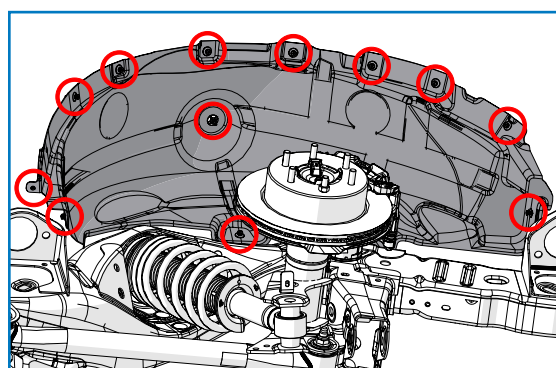

33

34 REINSTALL THE WHEELS

Install the wheels back on both sides of the vehicle and re-install factory lug nuts (as shown in Figure 34).

In a star pattern, torque lug nuts to 135 N•m [100 ft-lb]

Repeat on opposite side of the vehicle.

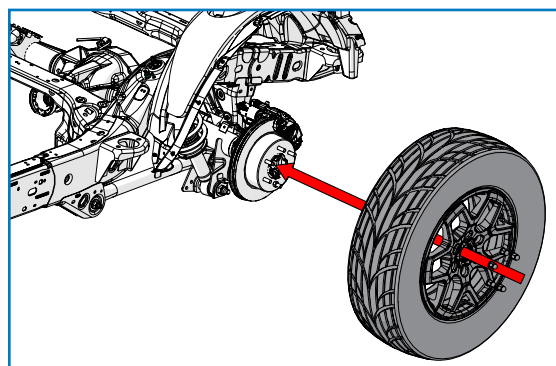

34

Congratulations!

You have completed the installation

POST INSTALLATION WARNING

After the kit installation is complete and the vehicle is on the ground at its normal ride height, roll the vehicle backward and forward to settle the suspension. Tighten all components containing rubber bushings to the specified torque values. Verify adequate tire, wheel, brake line and ABS wire clearance by turning the front wheels completely to the left and then to the right. Ensure brake/ABS lines are not stretched when the suspension is at full droop. Test and inspect steering, brake and suspension components. Vehicle damage may result if the post installation checks are not performed.

VEHICLE HANDLING WARNING

Larger wheel and tire combinations may increase the leverage on the suspension and steering components. Increasing the height of your vehicle increases the likelihood of rollover or loss of control during abrupt maneuverer, especially at high speeds. Operate your vehicle at reduced speeds in all conditions to prevent loss of control. Failure to do so may result in serious injury.

WHEEL ALIGNMENT & HEADLIGHT ADJUSTMENT

After the kit installation is complete, a professional wheel alignment must be performed by a certified alignment technician to re-align the vehicle to within factory specifications. Additionally, ensure that the vehicles headlights are aimed properly. If not, a headlight alignment is required as well. If not properly aligned it can cause increased tire and suspension component wear.

VEHICLE RE-TORQUE & SAFETY INSPECTION

After the kit installation and adjustments have been completed and within 50 miles of driving, perform a check over of all applicable fasteners and hardware to ensure they are adequately tightened to the specifications given (or as noted in the vehicle's factory service manual).

WARRANTY

To be eligible for warranty, the owner must submit their warranty card or register online within 30 days of the purchase date.

.....