



## Product Data Sheet



Doc. #	Rev.	ECN #	Date	Name
L8003	9	1-2653	07.12.22	Pamir Ozdemir

### Physical Characteristics

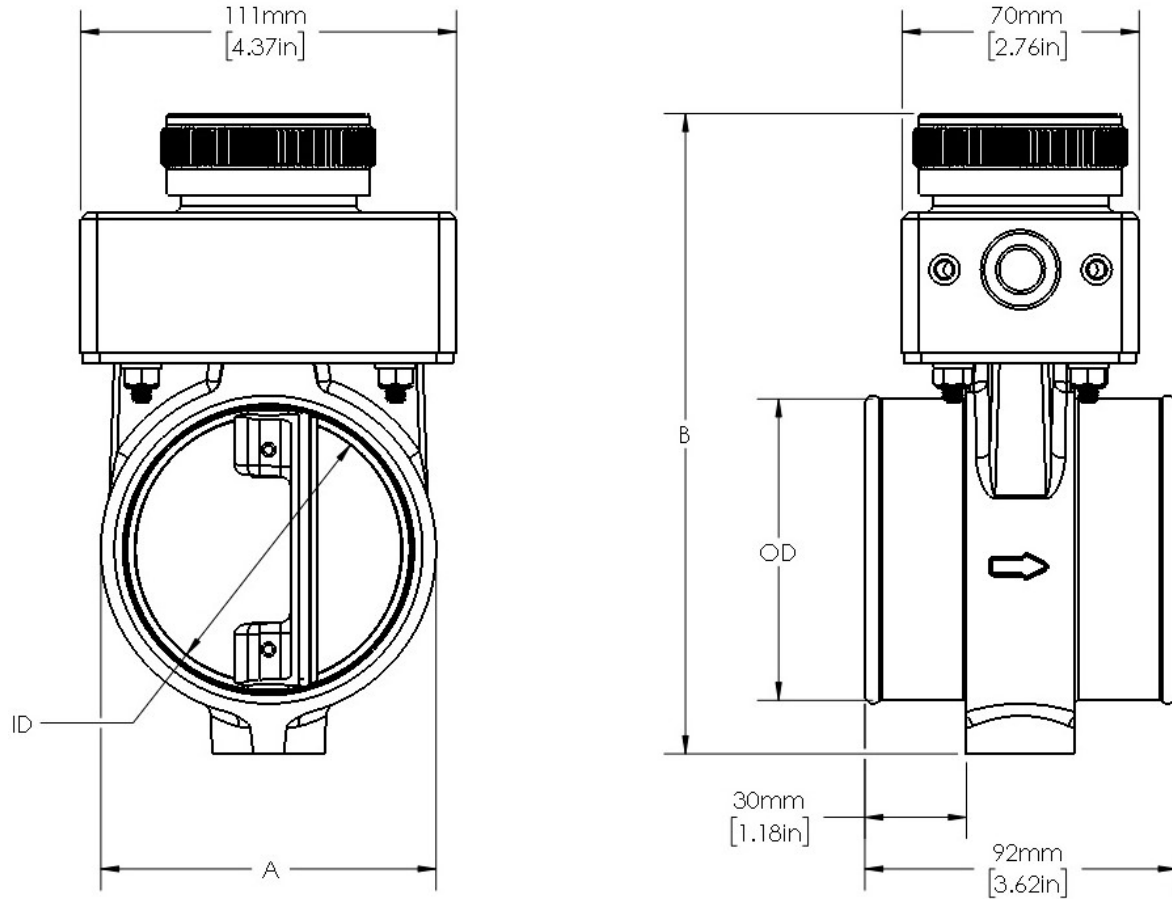

Nominal Valve Size [OD]	Valve Core Dimensions			Weight
	Bore [ID]	Width [A]	Height [B]	
<b>71.0 mm</b> [2.8 in]	58 mm [2.28 in]	81 mm [3.19 in]	176.3 mm [6.94 in]	1.46 kg [3.25 lb]
<b>76.2 mm</b> [3.0 in]	63 mm [2.48 in]	81.5 mm [3.20 in]	179.3 mm [7.05 in]	1.48 kg [3.26 lb]
<b>89mm</b> [3.5 in]	78.5 mm [3.09 in]	99 mm [3.89 in]	189.1 mm [7.44 in]	1.55 kg [3.41 lb]
<b>102 mm</b> [4.0 in]	91.5 mm [3.60 in]	112 mm [4.41 in]	202.1 mm [7.95 in]	1.64 kg [3.61 lb]
<b>127 mm</b> [5.0 in]	116.5 mm [4.59 in]	134 mm [5.27 in]	227 mm [8.94 in]	1.75 kg [3.86 lb]
<b>139.7 mm</b> [5.5 in]	126.5 mm [5.1 in]	151 mm [5.9 in]	238.1 mm [9.37 in]	1.96 kg [4.32 lb]

## Product Data Sheet



Doc. #	Rev.	ECN #	Date	Name
L8003	9	1-2653	07.12.22	Pamir Ozdemir

### Single Pull Cable Activation

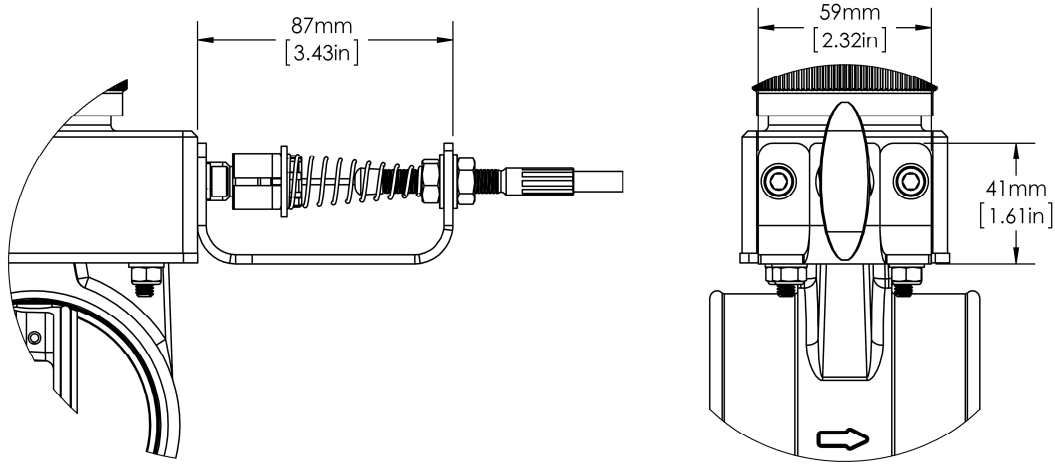

<b>Cable Activation Pull Force</b>	90 N [20.2 lbf]
<b>Minimum Stroke for Activation</b>	12 mm [0.47 in]
<b>Activation</b>	Pull to close
<b>Actuator Weight (Cable Weighed Separately)</b>	0.24 kg [0.53 lb]

### 12/24 VDC Electric Activation

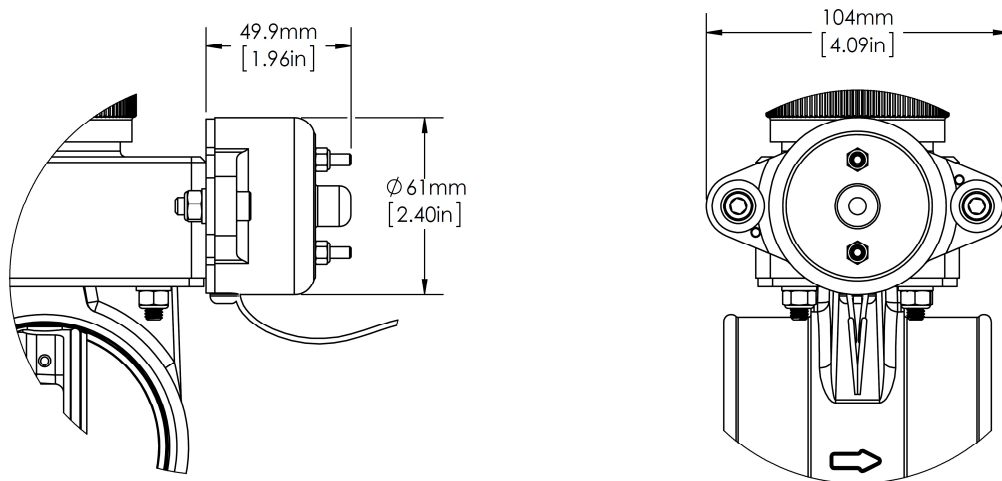

Voltages	12 VDC	24 VDC
<b>Resistance</b>	1.7 $\Omega$ +/- 10%	3.9 $\Omega$ +/- 10%
<b>Duty cycle</b>	10 sec ON / 90 sec OFF	10 sec ON / 90 sec OFF
<b>Activation</b>	Power to close	Power to close
<b>Electrical Connector</b>	Metri-Pack, 280 Series Female, 2 Pin (Delphi # 15300027)	Metri-Pack, 280 Series Female, 2 Pin (Delphi # 15300027)
<b>Actuator Weight</b>	0.84 kg [1.9 lb]	0.84 kg [1.9 lb]

All information contained in this document is for reference only, subject to change without notice

## Product Data Sheet



Doc. #	Rev.	ECN #	Date	Name
L8003	9	1-2653	07.12.22	Pamir Ozdemir

### 12/24 VDC Electric Solenoid with Single/Dual Pull Cable Activation

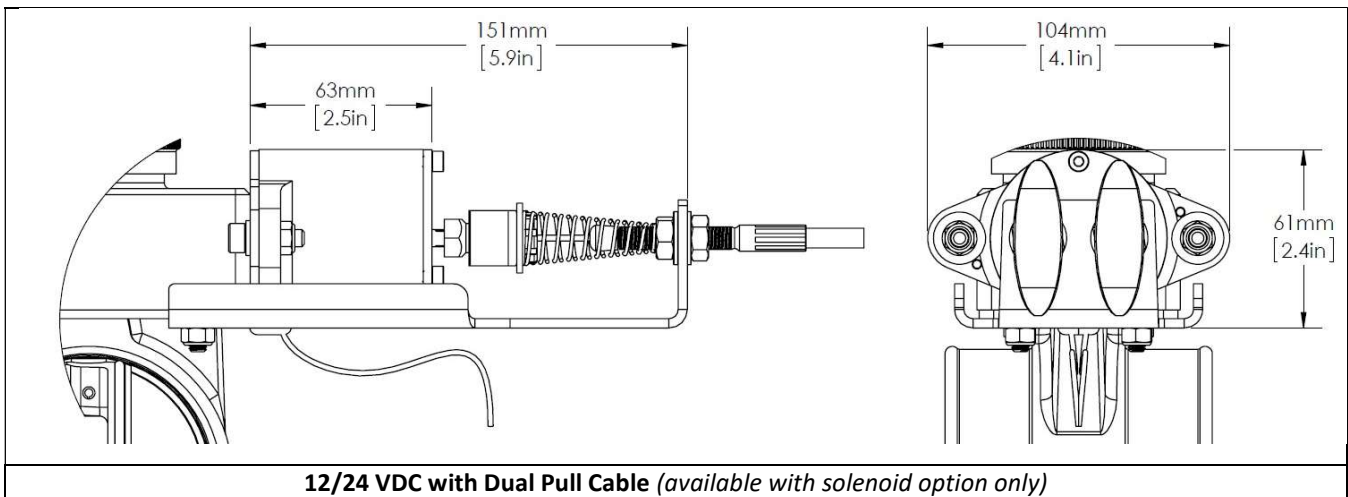
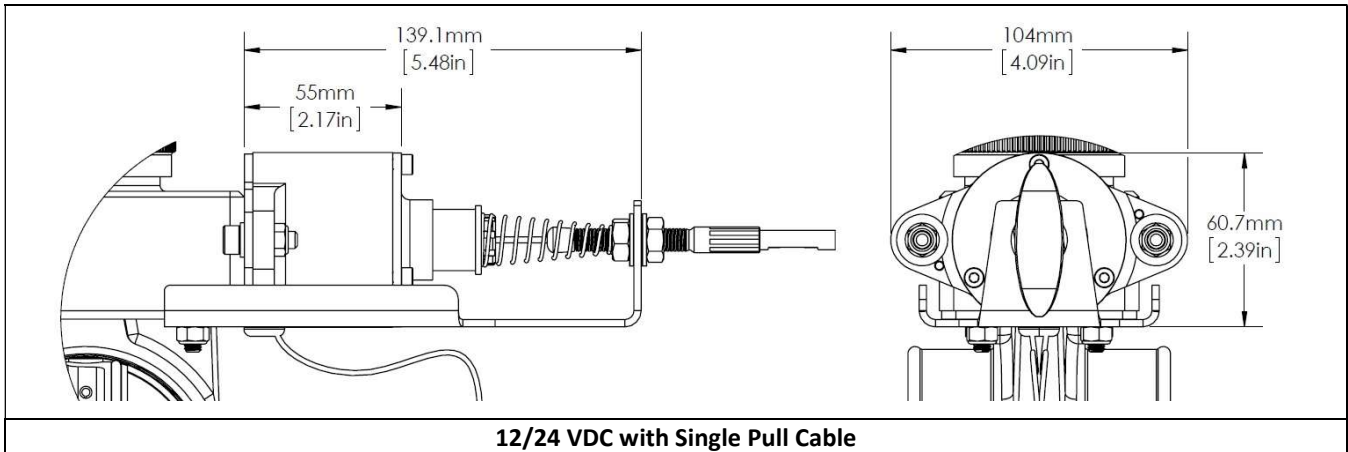

Pull Cable Configuration		
No. of cables	Single	Dual
Cable Activation Pull Force	90 N [20.2 lbf]	98 N [22 lbf]
Minimum Stroke for Activation	12 mm [.47 in]	12 mm [.47 in]
Activation	Pull to close	Pull to close
Electrical configuration		
Voltages	12 VDC	24 VDC
Resistance	1.7 Ω +/- 10%	3.9 Ω +/- 10%
Duty cycle	10 sec ON / 90 sec OFF	10 sec ON / 90 sec OFF
Activation	Power to close	Power to close
Electrical Connector	Metri-Pack, 280 Series Female, 2 Pin (Delphi #15300027)	Metri-Pack, 280 Series Female, 2 Pin (Delphi #15300027)
Actuator Weight (Cable Weighed Separately)	0.96 kg [2.1 lb]	1.08 kg [2.4 lb]

All information contained in this document is for reference only, subject to change without notice

## Product Data Sheet



Doc. #	Rev.	ECN #	Date	Name
L8003	9	1-2653	07.12.22	Pamir Ozdemir

### Pneumatic Activation

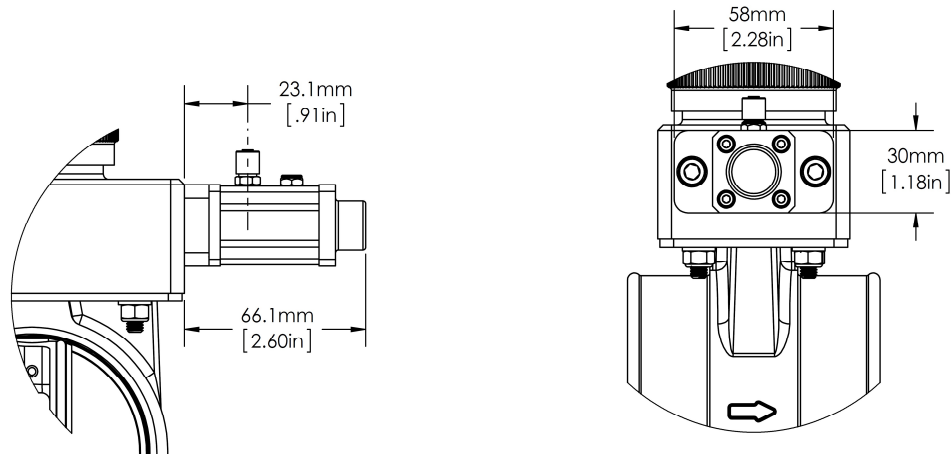

<b>Minimum Air Supply Pressure for Activation</b>	4.1 bar(gauge) [60 psig]
<b>Maximum Air Supply Pressure</b>	10 bar(gauge) [145 psig]
<b>Pneumatic Cylinder Temperature Range</b>	-40°C to +70°C [-40°F to +158°F]
<b>Pneumatic Connection</b>	Tube: 6 mm OD, 4 mm ID, nylon, soft nylon, or polyurethane
<b>Air System Cleanliness</b>	Contaminant particle size < 40 µm [ .16 µin]
<b>Activation</b>	Provide pressure to close valve
<b>Actuator Weight</b>	0.20 kg [0.44 lb]

### Pull Cable

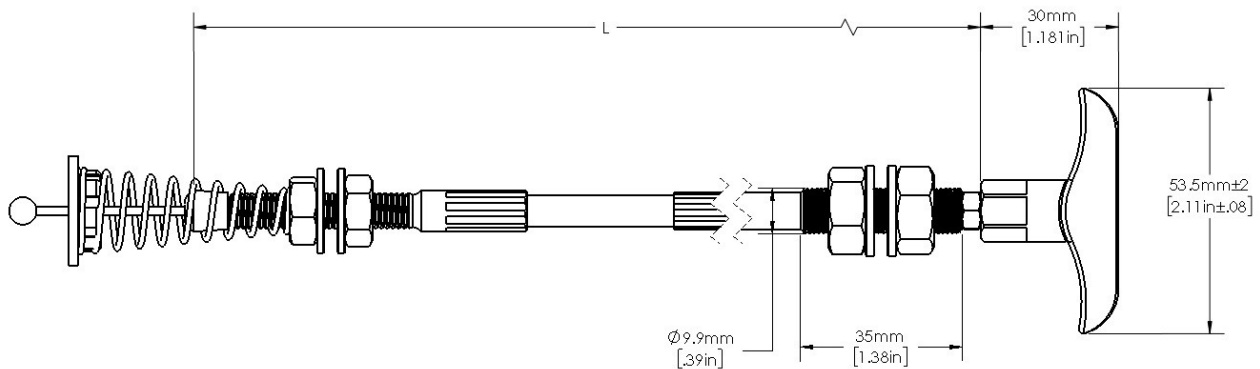

<b>Minimum Cable Bending Radius</b>	90 mm [3.54 in]					
<b>Cable Lengths [L]</b>	mm	610	1220	1830	2440	3050
	ft	2	4	6	8	10
<b>Default Position</b>	Handle retracted					
<b>Cable Weight (Reference)</b>	0.29 kg [0.64 lb] for 1830 mm [6 ft] Length					
<b>Total degrees of all bends</b>	360° maximum					
<b>Through-hole size</b>	11 mm [7/16 in]					

All information contained in this document is for reference only, subject to change without notice

## Product Data Sheet



Doc. #	Rev.	ECN #	Date	Name
L8003	9	1-2653	07.12.22	Pamir Ozdemir

### Digital Controller

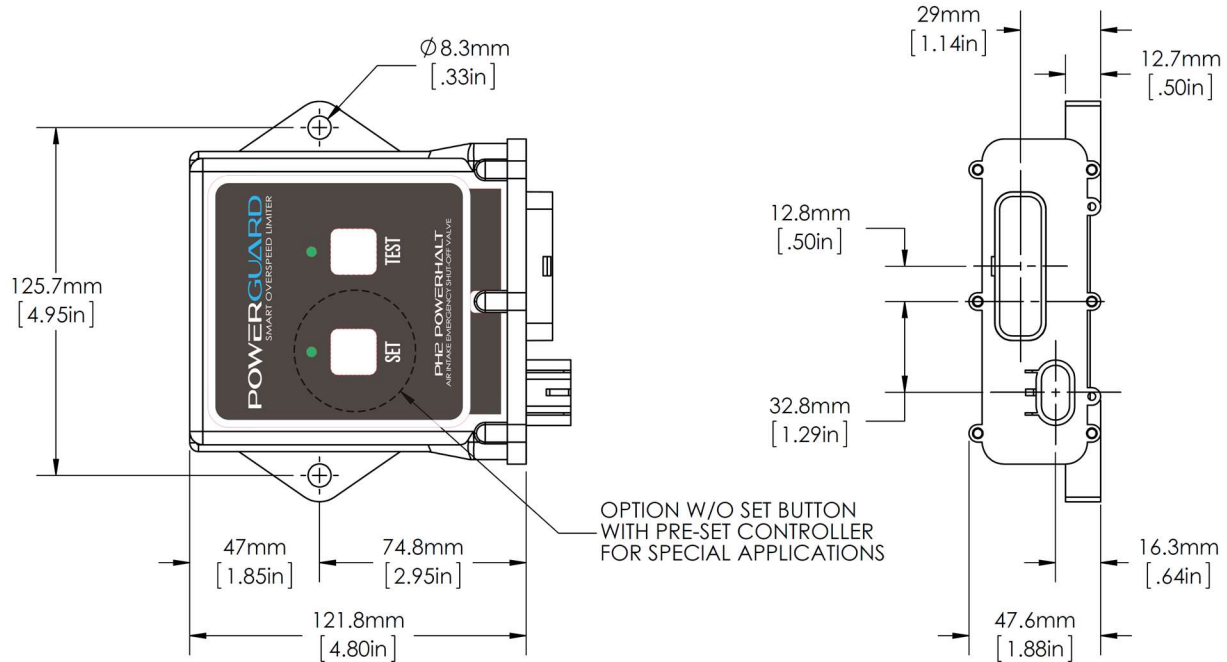

<b>Controller Housing Material Compliance</b>	J1455 (-40°C to +85°C) [-40 F to +185 F]
<b>Controller Voltage</b>	12/24 VDC
<b>Maximum Relay Rating</b>	20 A@28 VDC
<b>Power Consumption</b>	30 mA max continuous

### Magnetic Pickup – Gear Tooth Sensor

#### Sizes Available

Thread Size	Length	Installation Torque
3/8 - 24 UNF	51 mm [2 in]	5.1 ± 0.3 Nm [45 ± 3 in-lbf]
3/8 - 24 UNF	76 mm [3 in]	5.1 ± 0.3 Nm [45 ± 3 in-lbf]
5/8 - 18 UNF	51 mm [2 in]	25.8 ± 1.4 Nm [19 ± 1 ft-lbf]
3/4 - 16 UNF	64 mm [2.5 in]	81.3 ± 2.7 Nm [60 ± 2 ft-lbf]

<b>Temperature Range</b>	-40°C to +105°C [-40°F to +221°F]
<b>Signal Output</b>	0 VDC to 5 VDC TTL
<b>Connector</b>	Weather-Pack, Male, 3 Pin (Delphi # 12010717)

All information contained in this document is for reference only, subject to change without notice

## Product Data Sheet



Doc. #	Rev.	ECN #	Date	Name
L8003	9	1-2653	07.12.22	Pamir Ozdemir

### Toggle Switch

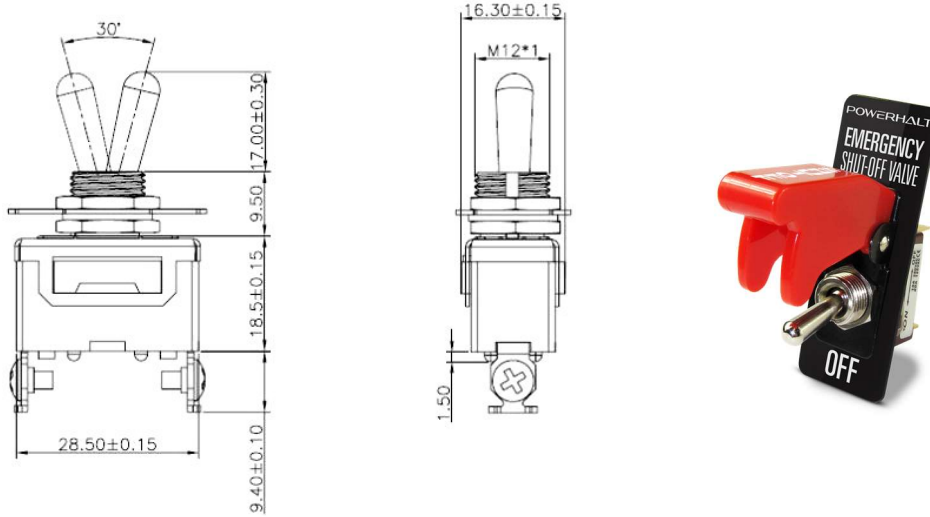

<b>Thru-Hole Drill Size</b>		12.7 mm [0.5 in]
<b>Temperature Rating</b>		-25°C to +80°C [-13°F to +176°F]
<b>Current Rating</b>	<b>12 VDC</b>	6.25 A
	<b>24 VDC</b>	3.13 A

### Hoses

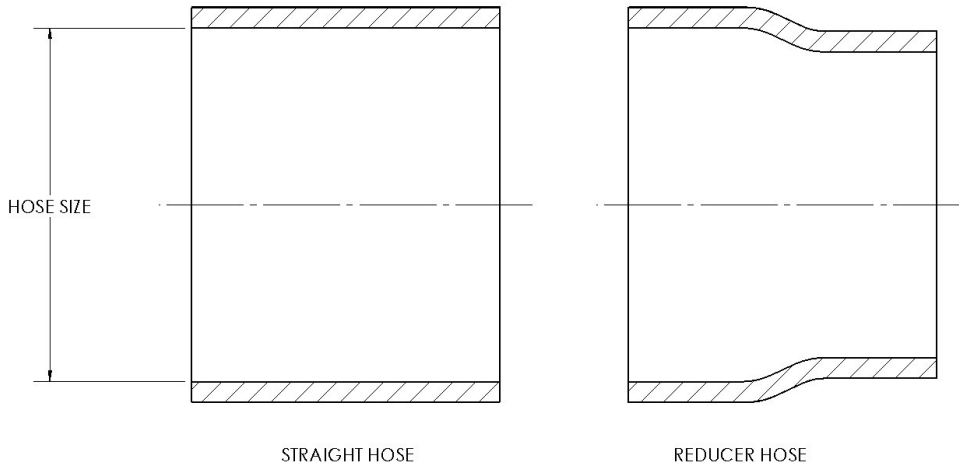

<b>Temperature Rating</b>	-55°C to +175°C [-67°F to +347°F]		
<b>Pressure Rating</b>	1 MPa [145 psi]		
<b>Hose Sizes</b>	63 mm to 140 mm [2.5 in to 5.5 in]		
<b>Hose shape available</b>	Straight	90° elbow	45° elbow

*All information contained in this document is for reference only, subject to change without notice*

## Product Data Sheet



Doc. #	Rev.	ECN #	Date	Name
L8003	9	1-2653	07.12.22	Pamir Ozdemir

### Clamps

<b>Description</b>	Spring Loaded T-Bolt, Heavy Duty/ SAE J1508 Type SLTB												
	Clamp, spring loaded constant tension gear/SAE J1508 Type SLF												
<b>SAE Sizes</b>	64	68	76	84	92	102	112	116	124	136	140	148	154
<b>Size Range</b>	73 mm to 152 mm [2.88 in to 6 in]												
<b>Installation Torque</b>	7.9 Nm [70 in-lbf]												

### Wiring Harness

<b>Temperature Rating</b>	-40°C to +85°C [-40°F to +185°F]
<b>Sealed Connectors</b>	Yes

### Pneumatic Solenoid for Pneumatic Activation

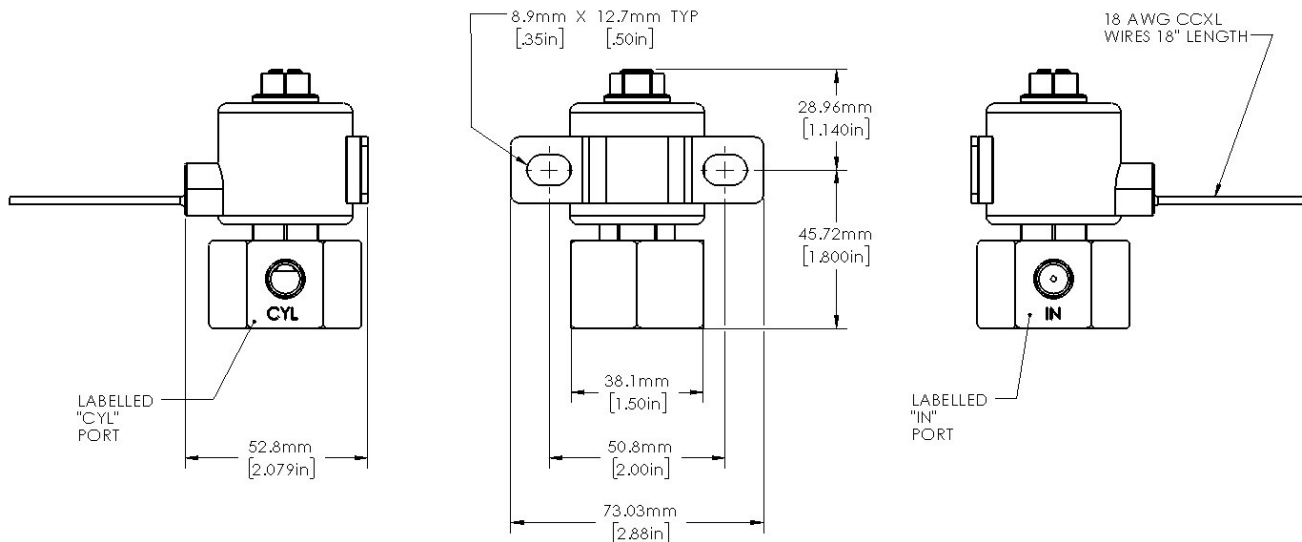

<b>Temperature Rating</b>	-40°C to +85°C [-40°F to +185°F]	
<b>Air Pressure</b>	10.34 bar (gauge) [150 psig] max operating pressure	
<b>Nominal Voltage</b>	12 VDC	24 VDC
<b>Current Rating</b>	1.5 A max	0.8 A max
<b>Connector</b>	Metri-Pack 280 (Delphi # 15300027)	
<b>Port thread</b>	IN	1/8 NPT
	CYL	1/8 NPT

All information contained in this document is for reference only, subject to change without notice

## Product Data Sheet



Doc. #	Rev.	ECN #	Date	Name
L8003	9	1-2653	07.12.22	Pamir Ozdemir

### Position Feedback Option

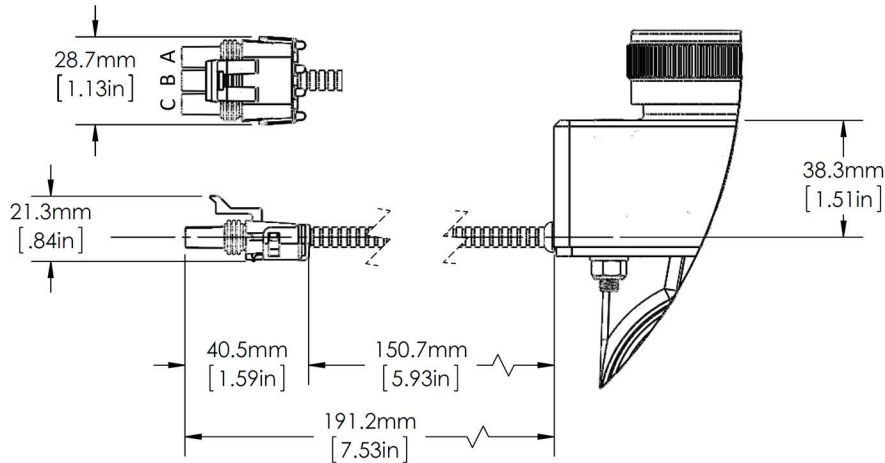

Pinout, Valve In Open Position	A = NO	B = COM	C = NC
Current Rating	3.0 A @ 30 VDC		3.0 A @ 125 VAC
Connector	Weather-Pack, Female, 3 Pin (Delphi #12015793)		

### Applications

- Lighting Units
- Bulk Haulers
- Grain Processing Plants
- Refinery Processing
- Fueling Vehicles
- Pump Trucks
- Ambulances
- Tankers
- Cranes
- Vehicles
- Tow Vehicles
- Fire Trucks
- Lighting Trucks
- Power Generators
- Forklifts
- Underground Equipment
- Support Vehicles
- Vacuum Trucks
- Frack Trucks
- Drilling Rigs
- Work Boats
- Barges
- Welders